



MALAWI GOVERNMENT

DEPARTMENT OF LANDS, VALUATION AND WATER

# GRAVITY FED RURAL PIPED WATER SCHEMES

## Rural Water Operator's Handbook



201-83GR-17007

REPUBLIC OF MALAWI

# GRAVITY FED RURAL PIPED WATER SCHEMES

## **Rural Water Operator's Handbook**

LIBRARY IRC  
PO Box 93190, 2509 AD THE HAGUE  
Tel.: +31 70 30 689 80  
Fax: +31 70 35 899 64  
BARCODE: 17887  
I.O.: 201 83GR

DLVW

## FOREWORD

It is now widely recognised that a good water supply is one of the vital factors in the advancement of rural communities in the developing world.

It is also the participation of the Community in the process of solving their own problem, which ensures the success of the project and develops the spirit of self reliance of the rural people.

This Rural Water Operator's Handbook and the Design Engineer's Manual, which goes with it are a record of the techniques which have been evolved out of experience in the development of Self-Help Piped Water Projects in Malawi over the past 16 years. First written in 1977, it has been revised with many additions in 1983. It has been compiled for the use of Operators who are constructing rural piped water projects. It can also be used as a training manual.

<u>CONTENTS</u>	<u>Page</u>
Preface	(i)
Background	(ii)
Rural Water Supply Systems	(ii)
Water Quality	(iv)
Outline of Piped Water Projects	(v)
Qualities of a Rural Water Operator	(vi)
1. <u>TECHNICAL INSTRUCTION AND PRACTISES</u>	1
1.1    MARKING TRENCHES	1
1.1.1  Marking a new line	1
1.1.2  Marking out for excavation	2
1.2    TRENCH DIGGING	4
1.2.1  Organisation and Standards	4
1.2.2  Maintaining the trench digging Programme	6
1.3    OVERCOMING OBSTACLES	8
1.3.1  Laterite	8
1.3.2  Flooding	8
1.3.3  Rocks	8
1.4    INSTALLATION OF ASBESTOS CEMENT PIPELINES	11
1.4.1  Background	11
1.4.2  Details of A.C. Pipes	11
1.4.3  Laying Organisation	12
1.4.4  Connecting A.C. Collar Joints	13
1.4.5  Checking	14
1.4.6  Backfilling	15
1.4.7  Flushing of A.C. Pipelines	15
1.5    FITTINGS USED ON A.C. PIPELINES	16
1.5.1  Description	16
1.5.2  Connection of A.C. Fittings	16
1.5.3  Cast Iron Fittings	18



1.5.4	Thrust Blocks	18
1.5.5	Requirements for Installation of A.C. Lines	19
1.6	PRESSURE TESTING AN A.C. MAIN	24
1.7	INSTALLATION OF PVC PIPELINES	26
1.7.1	Background	26
1.7.2	Details of PVC Pipes	26
1.7.3	Laying Organisation	27
1.7.4	Repair of Breakages	29
1.8	PVC FITTINGS	31
1.8.1	Description	31
1.8.2	Compiling a Fittings List	35
1.9	INSTALLATION OF STEEL PIPELINES	39
1.9.1	Background	39
1.9.2	Laying Procedure	39
1.9.3	Fitting Flanges	40
1.9.4	Joining Steel to PVC Pipes	40
1.9.5	Joining Steel to A.C. Pipes	41
1.9.6	Fittings List	41
1.10	PROTECTION OF A COMPLETED PIPELINE	42
1.10.1	Ridge Construction	42
1.10.2	Check Dams	42
1.10.3	Planting Paspalum Grass	43
1.11	VILLAGE TAP SITES	44
1.11.1	Siting of the Tap	44
1.11.2	Preparing of the Tap Site	44
1.11.3	Plastering the Apron and Drainage Channel	46
1.11.4	Issuing a Tap	47
1.11.5	Tap Opening Ceremony - Chichewa	49
1.11.5	Tap Opening Ceremony - English	51

1.12	REINFORCED CONCRETE TANKS	54
1.12.1	Function of the Tanks	54
1.12.2	Construction	54
1.12.3	Choice and Layout of Tank Site	55
1.12.4	Excavation	56
1.12.5	Quality of Construction Materials	56
1.12.6	Quality of Concrete	58
1.12.7	Supervision of construction	60
1.12.8	Completion of Tanks	61
1.13	RIVER AND GULLY CROSSINGS	69
1.13.1	Selection of a Crossing Site	69
1.13.2	Methods of Crossing	71
1.13.3	Supported Crossings	72
1.14	STORES PROCEDURE	75
1.14.1	Description of Stores	75
1.14.2	Ordering Procedures	75
1.14.3	Inventory Sheet	76
1.15	TRANSPORT	77
1.15.1	Control of vehicles	77
1.15.2	Loading and Off-loading	79
1.15.3	Relationship with Drivers	80
2.	<u>COMMUNITY PARTICIPATION AND USER EDUCATION</u>	83
2.1	INTRODUCTION	83
2.2	COMMUNITY PARTICIPATION	84
2.2.1	Reasons for Community Participation	84
2.3	THE RESPONSIBILITIES OF THE RWO	86
2.4	THE RESPONSIBILITIES OF THE COMMUNITY	86

2.5	THE RESPONSIBILITIES OF THE COMMITTEES	88
2.5.1	The Village Committee	88
2.5.2	The Branch Committee	89
2.5.3	The Main Committee	89
2.6	CONTACT BETWEEN RWO AND COMMITTEES	89
2.6.1	Paths of Communication	90
2.6.2	Difficulties with Committee members	93
2.7	USER EDUCATION	94
2.7.1	Introduction	94
2.7.2	Methods of User Education	94
2.7.3	Methods of Discussion	98
2.7.4	Water Related Diseases	100
2.7.5	Pollution	103
2.7.6	Advice to Maximise Health Benefits	104
2.8	ESTABLISHMENT OF STANDARDS	107
2.8.1	The RWO and his Family	107
2.8.2	Good Tap Sites	108
2.8.3	Influence of Committees	108
2.9	MAINTENANCE OF SERVICE LEVELS	109
2.10	REGULATION OF SUPPLY	

## APPENDICES

### "KALATA"

1.	Kalata ya Madzi kwa Anthu Onse	110
2.	Kalata yofotokoza za Madzi M'mipope kwa anthu onse	112
3.	Kalata kwa Atsogoleri Onse	113
4.	Malangizo a mipope ndi za kasamalidwe ka madzi akunwa	116
5.	Mafunso kwa anthu ofotokoza (okonza) mipope	118

## STANDARD REPORTING FORMS

1.	Tap Request Form	119
2.	Record of Breakages	120
3.	Tank Inspection Report	121
4.	Tap Inspection Report	122
5.	Stores consumption on maintenance	123

## DIAGRAMS

1.	P.V.C.Fittings	37
2.	Village Tap Apron	53
3.	Tank Inlet Connections (90 mm and above)	63
4.	Tank Inlet connections (75mm and below)	64
5.	Tank Outlet connections	65
6.	Suspended River Crossing	74

## TABLES

1.	R.C.Tank - Operator's check list	66
2.	R.C.Tank - Builders' checklist	67
3.	R.C. Tank construction material quantities	68
4.	Pipe Loading for 7 ton Pipe Carrier	81
5.	Loading Capacities - Construction Materials	82
6.	Paths of Communication	92

## Preface

This Water Project Operator Field Handbook is a practical guide for Operators and Supervisors working on gravity fed piped water schemes in Malawi.

It details instructions, and practises for most activities and responsibilities of Water Project Operators and Supervisors. It also provides the data necessary for efficient planning, organisation and implementation of Rural Piped Water Projects.

It is sub-divided into two sections:

- 1: Technical instructions and practises.
- 2: Community Participation and User Education.

The continuous evolution which characterises the Malawi gravity fed piped water schemes makes this Field Handbook no more than a "picture of today". New developments may later be incorporated into the text.

## Background:

A safe and convenient water supply is of paramount importance to human health and the well-being of society as a whole.

At present unsafe, polluted drinking water is still responsible for many diseases and indeed deaths in the rural areas of Malawi. Some of the diseases which are related to polluted water are as follows:-

- cholera
- typhoid
- dysentery
- hepatitis
- malaria
- scabies
- eye infections
- bilharzia

What is safe and convenient drinking water?

Safe and convenient drinking water is water that does no harm in any way and is pleasant to drink. This means that germs and toxic substances are absent, that there is no overdose of minerals or silt, that it has no colour, taste or smell.

## Water Supply Systems for Rural Areas

Rural water supply systems can be divided into three categories:

1. Wells
2. Gravity fed piped water
3. Boreholes.

### Wells

Dug wells are the traditional source of water for most people in Malawi although the well was often not more than a hole in the ground which was excavated deeper as the water table sank.

Protected dug wells are particularly suitable for areas with a relatively high ground water table (not deeper than about 10m) where gravity fed systems are not possible.

Although protected wells are supposed to produce safe water, it is often found that the water is not free from faecal infection.

Protected dug wells however are suitable for self help programmes.

### Gravity fed Piped Water Systems

Gravity fed piped water systems are applicable to densely populated areas with perennial mountain streams. One of the great advantages of piped systems is that the pollution danger from pit latrines, ground water and waste water is virtually absent. However it must be realised that pollution of the source will affect all consumers, and thus great care must be taken to prevent pollution at the intake.

Gravity fed piped water systems are appropriate for self help programmes. Although attention must be paid to proper organisation, motivation and supervision of the self help input.

Maintenance costs can be very low if the installation of the supply is undertaken to a high standard. An estimation of annual maintenance costs for large projects comes to about 0.6% of the construction costs or at about K0.10/head/year.

Although water from the source is safe, pollution can occur during the time between drawing water at the tap, and consumption of this water at the village houses. Traditionally a period of days may elapse between drawing water, and actually drinking it. It is part of the Operator's duty to emphasize the dangers involved in these practises, and to encourage the drawing of water for consumption on a daily basis.

### Drilled Boreholes

The drilling of boreholes requires mechanised equipment, and skilled labour. Because they are expensive to install and maintain, boreholes are normally restricted to areas where dug wells or gravity fed piped systems are not feasible.

Village Water Committees may be involved on a self-help basis in the construction of borehole aprons, drain channels and soak-away pits.

### Water Quality

In order to check that water is of good quality, Urban Water Boards continuously monitor water quality by means of specific laboratory tests. However water supplied by the Rural Piped Water Projects, is impounded in Forest Reserves, above the line of habitation. This should preclude any form of pollution, although the department regularly undertakes millipore testing, to detect any faecal pollution due to animals.

To improve the quality of water for consumption, it can be treated in a number of ways, both simple and complex. However since the water is impounded above the line of habitation or cultivation, then simple treatment processes are employed in the Rural Projects.

#### (i) Screening

This takes place near the point of abstraction, and removes the larger transported particles such as sand or gravel. It also removes any leaves or twigs which may have entered the inlet pipe.

#### (ii) Sedimentation

This allows the finer suspended particles to settle out during the time they are retained in the sedimentation tank.

#### (iii) Slow Sand Filtration

Following experimental work on a pilot project in Zomba, this has now been deemed a suitable method to be employed where the intake does not enjoy protected status.

(iv)



This form of filtration will remove any pathogenic pollution of the water by biological activity in the filter bed.

## Outline of Gravity Fed Rural Piped Water Projects

### Introduction

The Rural Piped Water Section supplies water to the rural areas of Malawi.

The Rural Piped Water Supplies are characterised by three features:

- (i) Water is free (it is a gift from God)
- (ii) The pipes are supplied by the Government
- (iii) The people supply all unskilled labour on a self-help basis.

After installation the supply is regarded to be the property of the people. Maintenance and operation are done by the local people with a skeleton support service from the Government.

In order to ensure that everybody shares equally, water has to be carried from the tap. Connections to the tap are not authorized, but taps are located in accordance with the wishes of the people. The systems are designed to provide each tap with a minimum flow of 270 litres/hour (one gallon per minute), with a maximum design population of 120 people for each tap. Proper care for, and diligent maintenance of these piped water systems, will ensure effective service throughout the design life of 20 years.

## Qualities required of a Rural Water Operator

### 1. Technique

A Rural Water Operator (R.W.O.) needs to be familiar with all current practises employed in the Rural Water Projects (R.W.P.).

This involves familiarity with the methods for laying Asbestos Cement (A.C.) and Polyvinylchloride (P.V.C.) piping, including marking, digging and backfilling of trenches.

In addition he should have the ability to connect steel pipes, and be familiar with all the fittings used, in conjunction with steel pipes, particularly those which have both metric and imperial dimensions. He should be prepared to apply these skills at awkward locations, such as river or gully crossings.

Familiarity with commonly used machines and instruments is also necessary, as well as building techniques employed.

### 2. Organisation and Planning

A R.W.O. is responsible for the proper organisation of the following:-

#### (i) Attendance

In order to maintain large attendances of Self-Help labour, it is necessary for the R.W.O. to work in close contact with the local leaders, such as Traditional Authority Chiefs, M.C.P. leaders, and the appointed water project committees.

In the case of falling attendances, the R.W.O. must contact these leaders in order to resolve the problems leading to poor attendance.

Only if these efforts fail does he resort to the assistance of his Supervisor. However a properly trained, and suitably motivated R.W.O., seldom has recourse to this alternative.

(ii) Self-Help Labour

Through the organisational efforts of the R.W.O., the local people attending for work should each have an allocated task. He should then ensure that each task is performed satisfactorily, and that no confusion or dis-harmony arises.

(iii) Planning

The R.W.O. should inform his Supervisor on a weekly basis, of his forthcoming requirements to facilitate steady progress of construction. These requirements include tools, fittings, transport, and any other specialist assistance needed.

3. Reporting

A R.W.O. adopts two methods of reporting progress; firstly through completion of the standard forms relating to the various aspects of construction, and secondly by a verbal report at the regular Staff Meetings.

4. Character and Attitude

The most important aspect of the success of RWO, is that he is respected by the community within which he works. To achieve this respect the following qualities should be observed:

- (i) Politeness : A polite and cheerful attitude will prevent dis-harmony. It is also wise for the RWO to remember that he is a guest in the community.

(vii)

- (ii) Honesty            An upright and honest stance, should always be maintained, even when under pressure to provide favours to local leaders. Weakness here will always be discovered as the people will report matters to the Supervisor.
- (iii) Enthusiasm:    The continued progress of work is dependent upon the enthusiasm of the RWO. Although he should guard against working too quickly and becoming exhausted in a short period of time. A steady and consistent attitude is far more satisfactory in the long-term.
- (iv) Maturity    :    This is an essential quality when dealing with Traditional and M.C.P. leaders. An immature attitude here will mean failure to convince these men of their responsibilities to the RWP, and subsequently their assistance will be forfeited.

Failure of a RWO to adhere to these guidelines will result in a poor relationship with the community within which he works. Subsequently his performance in his work will be unsatisfactory.

## 1. Technical Instruction and Practises

### 1.1 Marking Trenches

The first job of a RWO is to mark the trenches. Marking is done from aerial photographs onto which the trenches have been marked very accurately, and is divided into two phases.

#### 1.1.1 Marking a new line

The object here is to locate the trench on the ground in accordance with the aerial photographs, and to chain along its length in order to establish the quantities of pipes and fittings required.

- (i) Where possible the line should be marked in the dry season.
- (ii) The line should be as close as possible to that shown on the aerial photograph.
- (iii) The RWO should walk along the line before marking to check for obstacles such as large rocks or ant hills. River and gully crossings should be inspected and measured. Drawings of the proposed crossings, including a list of requirements must be handed to supervisor.
- (iv) In general the pipeline should be kept on a ridge, to have the branch lines running down hill, and to prevent air locks on high spots.
- (v) The line can be adjusted slightly to avoid obstacles, and to align with the chosen sites for river and gully crossings.
- (vi) Near a main road the line should be placed off the road to allow for future widening of the road. Follow telephone wires if possible.
- (vii) On sloping ground the line should be on the uphill side of the road and clear of drainage channels.

- (viii) To keep the line reasonably straight line up with a distant object such as a tree or a hill, and mark directly toward it.
- (ix) At least 10 village people are required for marking.
- (X) The line should be made straight by lining up 4 or 5 people spaced at about 30 pace intervals. If the undergrowth is tall long poles can assist.
- (xi) When the people or poles are lined up straight, fix marker sticks firmly to mark the line.
- (xii) Mainlines should be chained and pegged. Each peg, distance between pegs 100 ft., 30 m, should be numbered consecutively.
- (xiii) Chaining the line should be done after clearing in order to be accurate.
- (xiv) Marking, clearing, and chaining are preferably done in one day to avoid making more than one programme.

#### 1.1.2 Marking out for excavation

The object here is to prepare the line for digging, involving complete clearance of the ground, and division into appropriate sections for each village.

- (i) Marking out the line can be completed the day before the main programme is due to start, and can be done by project staff and a few local people. This avoids having hundreds of people waiting around the following morning while the beginning of the line is marked out for digging.
- (ii) The line ahead should be cleared of bush to a width of 2 m. for A.C.lines and 1.50 m for PVC lines.
- (iii) Line up strings parallel to each other. The assistance between the strings is 0.60 m for A.C. lines, and one hoe-width for PVC lines.

- (iv) Mark out the trench on the ground, by digging a line with hoes, as near as possible to the strings. Make sure that the lines are marked right up to the strings. This can be achieved by holding the string tight to the ground by standing on it or laying a piece of wood or stone across the string.
- (v) The line should then be divided into sections of about 10m. to be allocated to person.
- (vi) Initially, the village turn-out is likely to be abnormally large. It is essential that adequate preparations are made to ensure a smooth start to the programme. If there is chaos and confusion at the start, little progress will be made and the people will be discouraged. As many members of staff as possible should be present to prevent this.
- (vii) Tools, marking strings, measuring sticks for checking the trench depth, should all be delivered or prepared before hand.
- (viii) On the day the programme starts, send one leader ahead with about 20-30 people to continue clearing the line of bush, from where work stopped the previous day.
- (ix) Select another leader with about 10 men and teach them how to divide the trench into two or three metre sections.
- (x) Do not mark or dig at the position of gully or river crossings. This should be done immediately before the pipes are laid.

## 1.2 Trench Digging

### 1.2.1 Organisation and Standards

- (i) Before the digging programme starts, the RWO should draw up a digging timetable, for the villages on his line, in cooperation with the Section Committee. It is important to have a list of villages and populations, so that a balanced programme can be established.
- (ii) The introduction of the work to the leaders and people is very important and must be done properly. Enlist the help of local leaders from among the villages, to help organise the work. Do not take all the responsibility and organisation upon yourself.
- (iii) Select a number of leaders to receive people as they arrive for work, and to allocate each person to a section. This may be done according to the nature of the soil (e.g. 3 m. of a man, and 2 m for a woman for easy digging). The leader must explain that the people must finish their section before they can go.
- (iv) Village leaders should be given a measuring stick, and told to make sure that the trench is dug to full depth, and that nobody should leave before they have finished.
- (v) Project staff should assist the leaders and concentrate their efforts where problems are encountered, such as where rocks block the line, or difficult soil is present (e.g. laterite).



- (vi) After the day's digging, the RWO should inspect the trench to check depth, width, and straightness. The next day a few people may be allocated to tidy up any minor problems.
- (vii) Major problems will obviously not be solved in a day, and men should be allocated to work on these. It is very strongly recommended to try to overcome these problems at the time, rather than leaving them, with the intention of coming back later, (laterite hardens as it dries out and people get discouraged when they have to go back a long distance to clear up the trench).
- (viii) Problems concerning the organisation of the work, such as leaders not wanting their wives and children to go for work, or continuous low attendance of certain villages, should be referred to the Project Committee, but the authority of the RWO must be retained. He is always in charge at the trench and should not allow the villagers to dictate to him.
- (ix) Project staff should ensure tools are distributed as required. (Villagers bring their own hoes, the Project supplies pick, shovels, crow bars, axes and sledge hammers).
- (x) Trench depths:     1.20 m for AC lines  
                          0.75 m for PVC lines smaller than  
  75 mm.  
                          0.90 m for PVC lines above 75 mm.
- (xi) Earth should be heaped on the uphill side of the trench.
- (xii) Always measure the depth of the trench from the lower side.

- (xiii) Adjust the actual depth of the trench, in case of fluctuations in the ground level, to make the trench bed horizontal.

#### 1.2.2 Maintaining the trench digging Programme

- (i) If the programme has begun well, it will settle down to a steady rate of progree. Some villages may be weaker than others, but the Water Project Committee should resolve matters when this occurs.
- (ii) If the section is long and difficult, attendance at the trench may begin to drop after 2-3 months. This may be partly due to the harvest, and partly to waning of the initial novelty and enthusiasm. By this stage 75% of the section should be dug.
- (iii) When attendance falls, the chairman should call a meeting to discuss the problem, and to encourage the people to return. At this meeting it is important to stress the achievement so far, and to report progress on other sections. By this stage it should be possible to start laying, and it is a boost if a date can be fixed for the laying to start on a completed part of the trench. Once laying starts, the people are usually encouraged to work harder to finish the trench. It may be appropriate to reorganise the programme, so that each village is given a section remaining to be dug.
- (iv) If attendance continues to be unsatisfactory, the Committee should again meet to discuss the matter. It could refer to the Main Project Committee, which may ask the Chief and District Party Officials for help. The initiative for this should come from the Committee. The Party and Chief may then call a Public Meeting, after which attendance usually improves.

- (v) After digging has been completed, the programme must continue for laying and backfilling without delay, as otherwise excavated earth will begin to fall back into the trench, which will discourage the people, as they may have to re-dig their sections, before laying can take place.

### 1.3 Overcoming Obstacles

The following is a guide to dealing with the most common obstacles:-

#### 1.3.1 Laterite (ngaga)

Laterite has to be removed from the trench either with hoes, if it is soft, or with picks if it is hard. It is best to remove laterite as early as possible, to prevent it from hardening during the dry season.

#### 1.3.2 Flooding

Trenches are often waterlogged just after the rainy season, especially in dambo sections. If water is found, miss out the section, in order to allow the water to dry out, and the water table to sink. If water is still found at the end of August, or when pipe laying has reached the waterlogged section, two methods can be attempted to remove the water:

- (i) Dig a drain away from the lowest point of the trench, and drain the water away.
- (ii) Dam the trench in sections, and bail the water out of each section, just before laying. Lay immediately after bailing.

#### 1.3.3 Rocks

Rocks can be removed in four different ways:-

- (i) Manually using crowbars and rope.
- (ii) With a winch and pulley system (block and tackle)
- (iii) By successive heating and cooling, using fire, and water dousing.
- (iv) By blasting.

Most rocks can be removed by hand. Big rocks which cannot be removed in one piece can often be broken, using hammers and crow bars.

If rock is hard and too big for manual removal, the block and tackle can be used.

If a block and tackle is not available or if the rock is too big for the winch, the rock can be broken using fire. Instructions for rock burning are as follows:-

- (i) Remove soil from around the rock.
- (ii) Heap firewood carefully around the rock, especially near its base.
- (iii) Light the fire at dawn.
- (iv) After 5 or 6 hours remove all burning firewood and pour several buckets of water over the rock.
- (v) Attack the rock with sledgehammers.
- (vi) When cracks develop open them with a crowbar and pour on more water.
- (vii) Stop pouring water when the surface has cooled; and allow the surface to heat up again, from within, before pouring on more water.
- (viii) The burning process may have to be repeated for very large rocks.
- (ix) Some rocks break more easily than others. Rocks as big as a land rover, have been broken by this method.

Blasting is the last resort to remove rocks, and this course of action is decided upon by the Project Engineer, after all previously described methods have failed, or been deemed unsuitable.

## 1.4 Installation of Asbestos Cement Pipelines

### 1.4.1 Background

Assuming trench digging usually starts in March, the pipe laying should start in May/June, after the trench has been dug. Laying should be finished by October/November, before the start of the rainy season.

It is absolutely essential that the Asbestos Cement pipe lines are laid to the highest possible standards.

It is important that the laying team gets all the proper equipment to do the job. For example the absence of a supply of clean cloth, will affect the standard of joints adversely.

### 1.4.2 Details of A.C.Pipes

- (i) All pipes are 4 m. long.  
Pipe sizes are: 100 mm, 125 mm, 150 mm, 200 mm and 225 mm.
- (ii) The ends of the pipes are machined to exact size to receive the cement comet joint, and should be checked before joining.
- (iii) A.C. pipes are relatively heavy, and fragile. They should therefore be handled with care.
- (iv) Large size collars have a centre rubber ring which acts as a spacer between pipe ends. If the centre rubber ring for larger pipe sizes fits badly and prevents the pipe from being connected correctly, then it may have to be cut to make it fit. Centre rubber rings are not essential as a seal, but they prevent the pipes from

touching when expanding, and should therefore be fitted wherever possible. Rubbers of abnormal size or flexibility, (too soft or too hard, too thick or too thin) should be handed over to the Project Engineer, to be returned to the manufacturer for replacement.

#### 1.4.3 Laying Organisation

Efficient laying is largely a matter of organisation. The joints themselves, although obviously important, are the easiest part of the operation.

##### (i) Clearing

One leader, and a group of people should go ahead of the laying team clearing the trench of earth and debris.

##### (ii) Levelling

One leader, and a group of people should then backfill 3 inches (7 cm) of soft soil, and rake out trench bed to a smooth, soft, level surface. The levelling is very important and should be supervised by a member of the laying team. Boning rods are used to ensure that the level is exact. Unless otherwise directed by a supervisor, boning rods are compulsory.

##### (iii) Carrying of pipes

Another group should carry pipes from the dumps, and lay them end to end along the trench.



(iv) Preparation of Collars

The rubber rings should be inserted, and soaped at the dump. One prepared collar should then be placed alongside the trench at each joint. Although the setting of rubbers can be done by self help people, the RWO has to check every comet, plus rubbers before fitting to ensure that the rubbers are well placed.

(v) Lowering the pipes into the trench

Before lowering check that there is nothing inside the pipe. The first pipe to be lowered should be palced about half a metre from the previously laid pipe, to allow room for the joining procedure. The remaining pipes should be lowered in and placed end to end.

(vi) Joining

The joints themselves should be done by the laying team and do not require village labour. These joints can be connected when the people have left.

1.4.4 Connecting of Asbestos Cement Collar Joints

(a) Fitting of Collar

(i) Remove the 7 cm of backfilled soil from under the head of the pipe.

(ii) Clean inside of collar with rag

(iii) Cut length of centre rubber, and fit.

(iv) Clean and fit rubber rings, then apply soap.

(v) Clean pipe with rag, and apply soap.

- (vi) Push collar onto the pipe end with a crowbar, and check for square.

(b) Fitting of pipe

- (i) Check that the rubber ring is clean and soaped.
- (ii) Clean pipe end with rag, and apply soap.
- (iii) Push the pipe into the collar with a crowbar.
- (iv) Check that the collar is square, and central.

Equipment needed: Crowbar, soap, rag, wooden blocks, knife, boning rods.

NOTE: DO NOT ALLOW ANY STEPS TO BE LEFT OUT, AS THIS WILL RESULT IN LEAKAGES, OR EVEN BREAKAGES.

1.4.5 Checking

- (i) After joining check that the pipe ends are not touching. The machined ends should be visible for nearly 1 cm on either side of the collar.
- (ii) Check that the weight of the pipe is not resting on the collar. The collar should be clear of the ground.
- (iii) After laying a section of pipes, arrange them so that they lie in a straight line or a smooth gradual curve.

#### 1.4.6 Backfilling

All villages which are not engaged in the laying of pipes should be backfilling the trench. The backfilling is very important, but there is a danger that it will not receive the adequate supervision it requires because it may be a few hundred metres away from the laying. Backfilling of A.C. pipes can be divided into three separate stages as follows:-

- (i) Backfill with sufficient soft soil, to just cover the pipe and collar. This soil should be completely stone free, and compacted tightly around the pipe, using hands or feet. This is the most important of the three stages.
- (ii) Backfill to half the trench depth with the excavated soil, and compact it using feet.
- (iii) Backfill completely, using all the excavated soil, and form a ridge on top of the trench. This ridge should be discontinued at gullies, where rainwater should be allowed to pass freely.

#### 1.4.7 Flushing of A.C. Pipelines

If possible an A.C. pipeline should be flushed at intervals of one kilometre. This should be undertaken with the open end raised above the trench to avoid flooding.

## 1.5 Fittings used on Asbestos Cement Pipelines

### 1.5.1 Description

The following fittings are commonly used in the projects in conjunction with A.C.Pipes:-

* Short collar joint (Gibault joint)	* reducer
* saddle piece	* flange adaptor
* end cap	* double air valve
* hydrant tee piece	* single air valve
* tee piece	* sluice valve
* bends	* flush point.

### 1.5.2 Connection of fittings

- (i) The site of every fitting, on an Asbestos Cement line, should be marked at the trench with a label. These points should not then be back-filled until pressure testing is completed.
- (ii) The connection will either be made at the time of laying, or more usually, after the pipes have been laid. Reducers are connected after the pipeline has been flushed, to avoid debris left in the pipe accumulating at the reducer.
- (iii) Airvalves should be at high spots, and flush at low spots. Both are located following a longitudinal survey by the Project Engineer.
- (iv) All valves should be protected by prefabricated concrete culvert rings and a cover. The rings should be supported on a brick base (not on the pipe), and the top ring should protrude above ground level; 0.5 m diameter rings are suitable

for single air valves and sluice valves, whilst 0.7 m diameter rings are used for double air-valves.

- (v) Check the size and class of the Gibault fitting, and the pipes, to ensure that they are compatible. Special Gibault joints are available for reducing between different classes of A.C. pipes.

The colours to identify between the different classes are:-

Class 12	blue
Class 18	yellow
Class 24	green

- (vi) To test for faults in the fittings, inspect closely to see if any cracks are visible. Tap fittings with a spanner; a dull sound indicates that the fitting is cracked.
- (vii) Check that the correct bolts are used, and that they are available before work begins. The threaded part of the bolt normally points in the direction of flow. In the case of sluice valves, bolts are placed such that they can be tightened easily.
- (viii) If a fitting leaks, then it may be due to the bolts not being tightened fully or evenly, or to the rubber not fitting properly.
- (ix) Gibault joints, saddle pieces and end caps should always be collected complete. Check at the store that nothing is forgotten, before leaving for work.

### 1.5.3 Cast Iron fittings

The most commonly used Cast Iron fitting is the Gibault, or short collar joint. These are used to connect fittings such as bends, reducers, tees, flange adaptors and hydrant tee pieces. A gibault joint consists of two flanges with bolts, two rubber rings, and a centre collar. Fitting of Gibault joints should be carried out inside the trench as follows:

- (i) Check that a hollow has been dug in trench bed to accommodate the fitting.
- (ii) Slip a flange over each pipe end.
- (iii) Slip a rubber ring over each pipe end, and put it in position with a spacer. Do not roll this ring.
- (iv) Introduce pipe ends to collar, until the rubber rings touch the collar, with a gap between pipe ends.
- (v) Bring the flanges up to the rubber rings, insert the bolts and tighten evenly.

Equipment needed : Two spanners, and a Hacksaw.

NOTE: Gibault joints should be left exposed until the line has been tested.

### 1.5.4 Thrust Blocks

Wherever the pipeline changes direction, at a bend or junction, or reduces in size at a reducer or is closed at a sluice valve or endcap, then the pipe must be anchored by use of mass concrete.

- (i) In the case of a bend or a tee piece, (not a hydrant tee piece), the concrete must support the actual fitting in the direction of thrust, i.e. the concrete must touch the actual fitting.
- (ii) In the case of a reducer, a hydrant tee piece used horizontally (e.g. at flush points), or a sluice valve, the concrete should be applied to a "puddle flange" which is a short piece of pipe one metre long with a flange welded in the middle, the flange being cast into the concrete block.
- (iii) The concrete should itself be pushed against compacted earth, therefore do not excavate more than the space to be filled by concrete, otherwise it will be founded on soft backfill, which will settle.
- (iv) The concrete mass should be about one cubic metre (about one bag of cement with a concrete mixture of 6:3:1).
- (v) When casting concrete, care should be taken to keep all bolts clear of concrete so that the fitting can later be removed easily.

#### 1.5.5 Requirements for Installation of A.C.Fittings

Before the job begins check very carefully that all necessary equipment is available on site:

##### (i) Saddle piece Kit

- \* complete saddle
- \* jointing compound
- \* pot and water
- \* brace and
- \* cloth
- \* two spanners

(ii) Tee Piece Kit

The example quoted here is for a 150 mm equal tee, but will have to be suitably altered for other sizes.

- 1 N<sup>o</sup> Tee Piece 150 x 150 x 150 mm
- 3 N<sup>o</sup> Gibault joints 150/class 18 complete plus rubbers and bolts.
- 3 N<sup>o</sup> Flange adaptors (flange drilled to correspond with holes in steel flange).
- 1 N<sup>o</sup> puddle flange 6"
- 2 N<sup>o</sup> flanges 6"
- 1 N<sup>o</sup> sluice valve
- 12N<sup>o</sup> bolts and nuts
- 2 N<sup>o</sup> spanners for Gibault bolts and nuts
- 3 N<sup>o</sup> rubber gaskets ( $\frac{1}{4}$ " ) for flange connections.
- 1 N<sup>o</sup> knife to cut gasket.

(iii) Hydrant Tee Piece

These are used for the connection of flush point, which are situated at low points along the line, at regular intervals.

The purpose of a flush point is to remove any sediment which may have accumulated at a low spot on the pipeline.

It is basically a Hydrant Tee, controlled by a sluice valve. When the valve is opened water will flow quickly out of the main line, carrying any sediment with it.

- 1 N<sup>o</sup> Hydrant Tee Piece 150 x 75 mm class 18.
- 2 N<sup>o</sup> Gibault Joints 150/Class 18, with bolts and nuts.
- 1 N<sup>o</sup> Puddle Flange 3".
- 12N<sup>o</sup> Bolts.



- 2 N.º Flanges 3".
- 1 N.º Sluice Valve.
- 2 N.º Spanners.
- 2 N.º Rubber Gaskets
- Knife, Cloth, Jointing Compound

(iv) Reducer .

The example quoted here is for a reduction from 150 mm to 100 mm, and suitable alterations will be necessary for other sizes.

- 1 N.º reducer 150 x 100 mm/class 18.
- 1 N.º gibault joint 150 mm/class 18 with rubbers and bolts.
- 2 N.º gibault joints 100 mm/class 18 with rubbers and bolts.
- 2 N.º flange adaptors 100 mm/class 18.
- 1 N.º puddle flange 4".
- 2 N.º flanges 4".
- 1 N.º sluice valves 4".
- 3 N.º rubber gaskets.
- 1 N.º knife.
- 1 N.º hacksaw.
- 12N.º bolts plus nuts
  - jointing compound
  - cloth
  - water plus pot

(iv) End cap

- \* endcap plus rubber and bolts.
- \* spanners.
- \* hacksaw.
- \* water plus pot.
- \* cloth.

(v) Airvalves

Air trapped as small bubbles in the pipeline accumulates at high spots and can cause an airlock. Both single and double air valves release this air, single airvalves through a small nozzle, and double air valves release great quantities of air while filling the pipeline with water.

Air valves are sited at every high spot. A single airvalve is fitted to a saddle piece with a reducing bush ( $1\frac{1}{2}$ " x  $\frac{3}{4}$ " ) and a nipple ( $\frac{3}{4}$ " ). A double air valve is bolted onto the upward facing 3" flange of a hydrant tee piece with  $2\frac{1}{2}$  x  $\frac{3}{8}$ " bolts.

The symbol for a single air valve is V and for a double air valve is VV.

(vi) Control valves

Control valves are used in the event of breakages or repairs. In mainlines above 90 mm sluice valves are used as control valves. In all other instances gate valves are used.

The symbol for control valves is a green cross inside a green circle.

For protection and operation purposes all valves are inside prefabricated concrete rings and a cover (see drawings on tank connections). The rings should be supported on a brick base, not on the pipe, and the top ring should protrude above ground level. 0.5 m diameter rings are suitable for single air valves, and sluice valves. For double air valves 0.7 m rings are used.

When operating sluice valves or gate valves, great care should be taken to open, or close, very slowly. Rapid and jerky opening, or closing, may not only damage the valve, but may cause many breakages in the pipeline, due to the impact of the water being stopped suddenly, which is known as the "water hammer shock". It suggested to make half a turn of the key per minute.

1.6 Procedure for Pressure Testing of an A.C. Main

- (i) The pipeline should be filled with water and be allowed to flush, running full, for at least 24 hours before testing.
- (ii) Section to be tested should be as short as possible, usually between two sluice valves.
- (iii) A pressure gauge should be fitted to the line.
- (iv) After flushing, the downstream sluice valve of the section should be closed slowly, so that the pressure builds up slowly and evenly.
- (v) When maximum static pressure is reached, the upstream sluice valve should also be closed.
- (vi) The pressure gauge should then be observed . Initial pressure loss may be due to water absorption in the wall of the pipe. In this case full static pressure should again be attained, and the test started only when it is certain that wall water absorption is complete.
- (vii) If the line maintains full static pressure for 6 hours, it can be pumped up to test pressure by using a hand test pump. The line should be tested to 75% of the manufacturers test pressure or to 150% of the maximum static pressure, whichever is the less.
- (viii) The test is satisfactory if the test pressure is maintained overnight.

- (ix) For a long section of large diameter pipe, the hand pump will be inadequate. In this case, the maximum static pressure must be maintained for 72 hours, for a satisfactory test.
- (x) Breakages may be due to faulty manufacture, faulty handling or faulty laying. Leakages are usually due to faulty laying. A common reason for leakages, is displacement of rubber rings inside the joints, this displacement occurs when pushing the A.C. pipes "home" too quickly.
- (xi) The purpose of the test, is to expose the weakness in the main line, so that they can be repaired while project staff are still around, and before the supply is connected to the consumers.
- A full record of the test procedure should be kept, including details of any leakages or breakages detected.

## 1.7 Installation of PVC Pipelines

### 1.7.1 Background

Assuming trench digging usually starts in March, the pipe laying should start in May/June when most of the trench has been dug. Laying should be completed by October before the onset of the rains.

Initially efforts are concentrated on installing the main line, with branch line digging, and laying usually proceeding once the main line is completed. If care is taken at gully crossings and obstacles, laying need not necessarily be delayed during the rainy season.

Delivery of P.V.C. pipes along the lines is done before the actual laying starts. Preferably the bigger sizes, and if possible the smaller pipe sizes also are delivered to the lines by pipe carrying lorry, which is by far the most efficient method of distribution. The RWO is responsible for informing the supervisor of the programme for pipe deliveries.

### 1.7.2. Details of PVC Pipes

- (i) Pipe sizes used vary from 160 mm diameter to 16 mm diameter, although all pipes are 6 m long.
- (ii) P.V.C. pipes can be joined in 2 ways, with solvent cement which is a chemical joint, or with rubber rings.
- (iii) P.V.C. pipes must always be stored in the shade. Sunlight makes the pipes brittle and weak. When delivered to the project, pipes can be stored inside an iron roofed shed, under bamboo mats, or in the shade of trees along the branch lines.

When storing large quantities of pipes for long periods, they should be stacked neatly in layers, each layer lying perpendicular to that directly below it. Heads should be alternated to ensure an even stack. Maximum stack height normally is 1 m for nested pipes. The stack height for the bigger pipe sizes may go up to 1.5 m, if there is only one pipe size in the stack.

### 1.7.3 Laying Organisation

#### (i) Clearing

A group of people should go ahead, clearing the trench of earth and debris.

#### (ii) Levelling

Before laying, the RWO should walk down the line, and check that the trench is dug fully to 0.75 m (2' 6"), or 1 m for pipes above 75 mm. The trench should then be levelled properly, using soft soil as a bedding for the pipes. Often little attention is paid to the levelling of trenches, which is one of the major reasons for subsequent breakages.

#### (iii) Carrying of Pipes

Another group should carry pipes from the nearest pipe dump, and lay them end to end along side the trench, with heads facing toward the source of water. The trench should be fairly straight. If you pick up the pipe at the middle, you will see how much it will be allowed to bend when laying.

i

(iv) Placing in the Trench

For rubber joints, the pipes may be laid into the trench immediately after joining.

For solvent cement joints, the pipes should not be laid in the trench for at least 30 minutes after joining.

For solvent cement joints joined after 9 a.m., the pipes should be left along side the trench, and not be lowered into the trench until the next morning.

It is good to cover the joints themselves with some soil, to prevent the freshly made joints from becoming hot.

(v) Backfilling

Ensure that soil is properly compacted around the pipe, and not just loosely dropped into the trench.

Ensure that the pipe is not laid on sharp stones, and that the backfill material does not contain any stones. Sharp stones can cut the pipe as it vibrates when carrying water, or when soil is being compacted above it.

Pipes with solvent cement joints should not be backfilled after 9 a.m. This is to avoid breakages at joints because of contraction, due to changes in temperature. A line 1 km long can expand or contract by almost 1 m during a change in temperature of  $10^{\circ}$  C.

Rubber jointed pipes can be backfilled at any time, as the contraction can be taken up at each joint.



All soil from the trench should be backfilled, and heaped over the pipeline to make a prominent ridge.

The ridge should not extend accross gullies or waterways. These should be left free for rainwater to cross unhindered.

(vi) Flushing

Eight hours after joining the pipes, water can be turned on to flush the pipeline. This should be done as frequently as possible, and always before any reducer or Tee connection is fitted. The open end of the line should be lifted out of the trench to prevent flooding.

1.7.4 Repair of Breakages

Breakages on P.V.C. lines are repaired by removing the broken piece of piping, and inserting in its place a piece which has been cut to size, and which has heads formed on both ends.

Before removing the broken piece of piping, the water is switched off at the nearest control valve upstream, and the line allowed to empty. The procedure to adopt in the case of a breakage is as follows:-

- (i) Turn off water at nearest control valve upstream, and allow the line to empty.
- (ii) Expose the section of pipe which is leaking.
- (iii) Cut out broken length of pipe.
- (iv) Cut a piece from a new pipe of the same diameter, of similar length but allowing 100 mm at either

end to form the heads.

- (v) Form heads on this piece of pipe by heating the ends on a fire, and pushing another piece of pipe into them whilst they are still hot and flexible.
- (vi) Fit the new piece of pipe using solvent cement joints, in the normal fashion.
- (vii) Switch the water on at the control valve, and check to see that the repair has been successful.
- (viii) Backfill after the water has been on for an hour, and the repair is showing no signs of leaking.

## 1.8 P.V.C.Fittings:

### 1.8.1 Description:

The different types of PVC fittings employed at the Rural Water Projects are numerous. It is due to this great variety of fittings that they often present great difficulties to the RWO.

However the sizes are marked on all the fittings, and these should always be checked before setting off for work. The RWO should prepare a list of fittings required, and give it to the Supervisor well in advance of the fittings being needed. He should keep a duplicate of this list, and then double check with it when the fittings arrive. The various fittings used are shown in the diagrams, and a brief outline of their uses is given below.

#### (i) Elbow 90° (F/F)

This is a Female/Female (F/F) fitting, which means that the pipe fits inside it at both its ends. These are used where the direction of the pipeline is to be altered. For larger sizes the elbow will need to be held in a thrust block of concrete, to support the pipe against the pressure of the water as it changes direction. Sizes available vary from 20 mm up to 140 mm.

#### (ii) Equal Tees 90° (F/F/F)

These are used at a junction in the mainline or a branch line, where the sizes of both lines are the same.

Here too the pipes will fit inside the Tee as it is a (F/F/F) fitting.

Where Reducing Tees are unavailable, then an Equal Tee can be used, with a Reducing Bush, which will alter the outlet size to that required for the size of the branch from the mainline. Sizes range from 20 mm to 140 mm.

(iii) Reducing Tees 90° (F/F/F)

Where the line is joined by a branch of smaller size a Reducing Tee will be used. It is a (F/F/F) fitting, where the larger diameter is the size of the mainline, and the smaller the size of the branch. The largest size of any Reducing Tee is 63 mm, as above this size saddles should be used. For a reduction from 50 mm to 32 mm, the notation for the Tee would be 50-32-50 mm.

(iv) Sockets (F/F)

These are used for the connection of PVC to steel pipes. One end of the socket will accept the PVC pipe in a normal solvent cement joint, whilst the other is internally threaded, and will be screwed onto the threaded end of a steel pipe. A typical example of their usage is to connect a tap-unit to the incoming line, where the socket used would be 20 mm by  $\frac{1}{2}$ ".

(v) Reducing Sockets (F/F)

Where the line is to change diameter, from a large size to a smaller one, then this can be done by fitting a reducing socket.

Again it is a (F/F) fitting, with the pipe being fitted into the socket at both ends. It is normal to give the larger size first when quoting a socket needed, and for reducing from 50 mm to 32 mm the notation would be 50-32 mm Reducing Socket.

(vi) Reducing Bushes (F/M)

With the Female/Male, (F/M), Reducing Bush, the pipe size is reduced by fitting the larger pipe into the Female end of the bush, and by fitting the smaller Male end of the bush into the smaller pipe. The male end of the Reducing Bush is called a Spigot End. The notation is the same as for a reducing socket 50-32 mm Reducing Bush.

(vii) Reducing Bushes (M/F)

These are usually called "short pattern" Reducing Bushes, and they take the form of a small piece of pipe, which has a thicker wall at the outlet end, from that at the inlet end.

The Male end fits into the larger size pipe, with a normal solvent cement joint, before the smaller size pipe is fitted into the Female end of the Reducing Bush.

(viii) Saddle Pieces (F/F/F)

For sizes of mainline or branchline larger than 63 mm, then a saddle piece is used in place of a reducing tee, to reduce to the size of the branchline. The pipe first has to be drilled to the diameter of the outlet, before the saddle piece is bolted over the top.

The pipe is always drilled on top, and the saddle fits in the vertical position. The pressure of water in the pipe will force it out through the hole in the top of the pipe.

(ix) Endcaps

Endcaps are used to block the end of a line, and have one Female end. They are fitted in a normal solvent cement jointing procedure.

They can be used to block the end of a line which is already supplying taps upstream, but does not yet have taps connected downstream, and there is no gate valve to be fitted nearby. Another use could be to block a branchline before it is due to be laid. The reason for this would be that the people from the branch would be still required to work on the main line, or at a tank site. By fitting an endcap, the RWO can place the Reducing Tee needed for the branch as he is laying the mainline, which would save the operation of cutting the main line, when he comes to lay the branch.

When he does come to lay the branch, the RWO saws off the endcap and discards it.

(x) Adaptor (F/M)

This is a fitting which is used in the connection of PVC and steel. The Female end accepts the PVC pipe in a normal solvent cement joint, whilst the Male end is threaded, and is able to screw into the steel fitting.

The most common use for these adaptors is the connection to gate valves, where they simply screw into the valves themselves. They are also used at flush-points, where they screw into the female end of the steel tee. Another use is in the fitting of air valves.

### 1.8.2 Compiling a Fittings List:

The example given here illustrates the way in which to compile a list of fittings, required for a particular section of line.

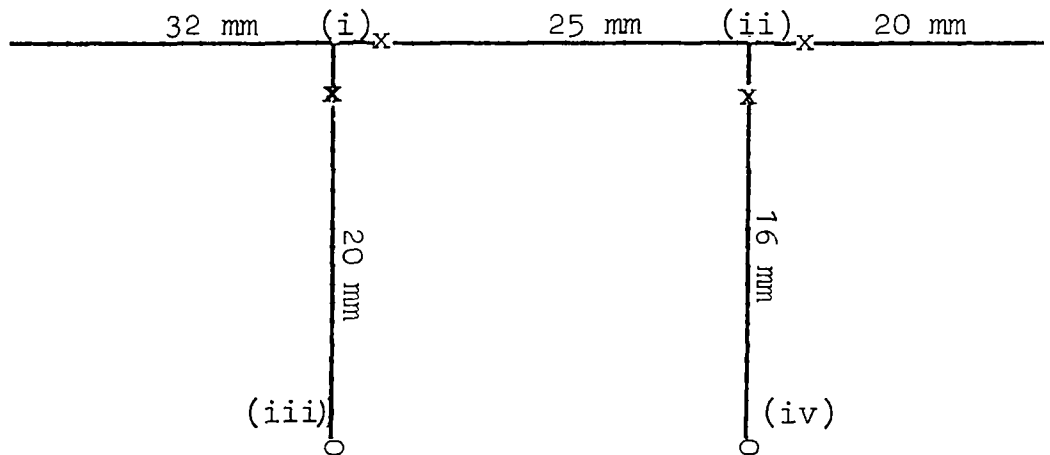

Consider the fittings needed at the four points marked, and systematically list the fittings.

- (i) Here the line is reducing from 32 mm to 25mm, as well as branching off to a 20 mm tap connection. Gate valves have to be fitted as the branch is reducing in size, and they are also needed on all lines leading to taps.

The fittings needed will be as follows:

- \* Reducing Tee 32-20-32 mm
- \* Reducing Bush 32-25 mm

- \* Gate Valve  $\frac{3}{4}$ ".
- \* Two F/M Adaptors 25 mm by  $\frac{3}{4}$ "
- \* Gate Valve  $\frac{1}{2}$ ".
- \* Two F/M Adaptors 20 mm by  $\frac{1}{2}$ ".

(ii) Here the line is being reduced from 25 mm to 20 mm, as well as branching off to a 16 mm tap connection. Therefore the gate valves will again be needed. The fittings needed then are:-

- \* Reducing Tee 25-20-25.
- \* Reducing Bush 25-20 mm.
- \* Two Gate Valves  $\frac{1}{2}$ ".
- \* Four F/M Adaptors 20 mm by  $\frac{1}{2}$ ".
- \* Reducing Bush 20-16 mm.

(iii) Here the standard fittings for a 20 mm tap connection are needed.

- \* F/F Adaptor 20 mm by  $\frac{1}{2}$ "
- \* Tap Unit.
- \* Bibcock  $\frac{1}{2}$ ".
- \* Plug  $\frac{1}{2}$ ".
- \* Spare washer  $\frac{1}{2}$ ".

(iv) Here it is the standard fittings for a 16mm tap connection.

- \* F/F Adaptor 16mm by  $\frac{1}{2}$ ".
- \* Tap Unit.
- \* Bibcock  $\frac{1}{2}$ ".
- \* Plug.
- \* Spare Washer.

By systematically considering a section of line in this way the RWO can always compile a comprehensive list of the fittings to be used.



# P V C FITTINGS

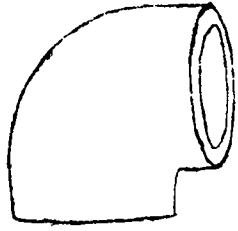

(i) Elbow 90° (F/F)

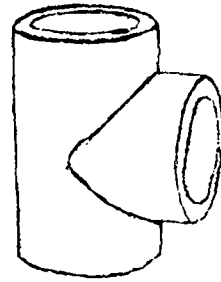

(ii) Equal Tee (F/F/F)

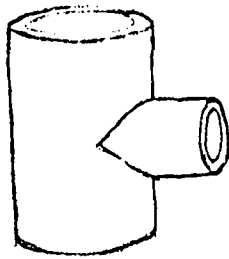

(iii) Reducing Tee (F/F/F)

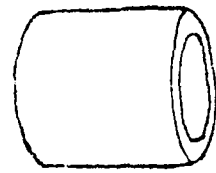

(iv) Socket (F/F)

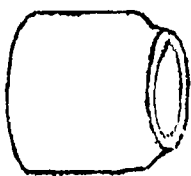

(v) Reducing Socket (F/F)

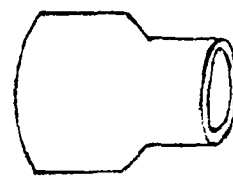

(vi) Reducing Bush (F/M)

# P V C FITTINGS

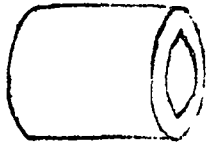

(vii) Reducing Bush (M/F)

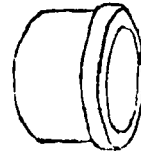

(ix) Endcap

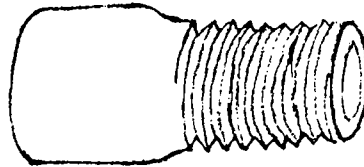

(x) Adaptor (F/M)

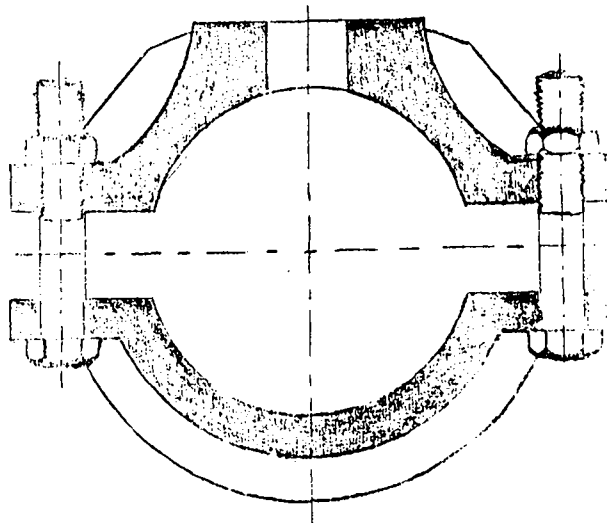

(viii) Saddle Piece (F/F/F)  
Cross section

## 1.9 Installation of Steel Pipelines:

### 1.9.1 Background:

Commonly used sizes of steel pipes are, 6", 4", 3", 2½", 2", 1", ¾", ½", with all pipes being 6 m long. These pipe sizes are internal diameters, whereas the sizes given for PVC pipes are external diameters.

Steel pipes are used whenever the pipeline is exposed, such as at river intakes or gully crossings. They are also used for road and river crossings, where although they are buried there is a possibility of damage.

These pipes are threaded at both ends, and care must be taken whilst handling them not to damage these threads.

Steel pipes are strong enough to support themselves over a span of a single pipelength. However for longer spans, the pipeline must be supported by pillars, at a maximum spacing of 12 m.

### 1.9.2 Laying Procedure:

- (i) Equipment necessary is as follows :- Wire brush, hacksaw, 2 pipe wrenches, jointing compound, spanner, rubber sheeting for gaskets.
- (ii) Remove rust and dirt from the threads of both pipes and sockets, with a wire brush (damaged threads can be repaired with a hacksaw).
- (iii) Spread jointing compound evenly around the end of each pipe to be joined and inside the socket

- (iv) Screw the socket onto one pipe end.
- (v) Carefully line up the next pipe and screw it into the socket.
- (vi) Tighten with pipe wrenches.

#### 1.9.3 Fitting Flanges:

- (i) Prepare the pipe ends and threads of flanges as above.
- (ii) Screw the flanges onto each pipe end.
- (iii) Cut out a piece of rubber sheeting and make holes in it for the bolts.
- (iv) Bring the flange faces together with gasket in between.
- (v) Insert bolts and tighten up evenly, tightening each bolt a little at a time.

#### 1.9.4 Joining Steel to PVC Pipes:

- (i) For PVC pipe sizes ranging from 16 mm to 63mm, Female/Female (F/F) adaptors are used for the connection.
- (ii) For PVC pipe sizes greater than 63 mm, a Male/Female adaptor and a steel socket are used. The socket is fitted to the end of the steel pipe, and the adaptor carefully screwed into place. The PVC pipe is then joined to the Female end of the adaptor with a normal solvent cement joint.

#### 1.9.5 Joining Steel to A.C. Pipes:

- (i) Bolt a flange adaptor to the A.C. Pipe.
- (ii) Fit a steel flange to the steel pipe as described above.
- (iii) Prepare a gasket cut from the rubber sheeting.
- (iv) Bolt the flange and flange adaptor together with the gasket placed between them.

#### 1.9.6 Fittings List:

The following are fittings which will be used in conjunction with steel pipes:-

- \* Sluice Valve
  - \* Gate Valve
  - \* Float Valve
  - \* Socket (F/F)
  - \* Nipple
  - \* Union
  - \* End Plug
  - \* Tees, Equal and Reducing
  - \* Flanges
  - \* Reducing Bushes
  - \* Reducing Sockets
  - \* Elbows (F/F)
- \* Various bends (M/M) cut to size, made to the angle required and thread at both ends.

## 1.10 Protection of a completed Pipeline:

Following the completion of laying and backfilling it is essential to protect the line from damage. This damage could be the result of people cultivating over the line, or from soil erosion by surface water. The following methods are used to protect the line from damage.

### 1.10.1 Ridge Construction:

The backfill soil should be heaped over the line to form a ridge which is larger than the surrounding cultivation ridges.

People must not cultivate directly above the line, however they must be instructed that their garden ridges should join the pipeline ridge. This prevents surface water from running alongside the line and causing erosion.

### 1.10.2 Check Dams:

Where the pipeline crosses the routes of surface water flow, such as at gullies, check dams should be constructed.

The check dams should be built of large stones, and located just downhill of the pipeline. The reason for this is that although rain water is allowed to flow over the line it is prevented from cutting back and exposing the pipe. Check dams should be constructed immediately after backfilling, as otherwise it may prove difficult to persuade the people to return when they think that they have completed their section.

Following the first rain the whole line should be examined, and the points of weakness established. To strengthen these points of weakness it may be necessary to construct more check dams, or to backfill and compact the soil more thoroughly. Further checking should take place following each rainfall.

#### 1.10.3 Planting of Paspalum Grass:

The location of the pipelines is clearly marked by the planting of paspalum grass. This particular grass is selected as it is drought resistant, and will dominate the surrounding undergrowth.

The main line in particular should be located in this way, and a special planting programme arranged.

## 1.11 Village Tap Sites:

As the village tap is the most important part of the project, it is essential that the tap site is well prepared and well maintained.

Once a village has been allocated its tap it is difficult to persuade the people to undertake further tasks. Therefore a tap is connected only after all jobs are completed.

### 1.11.1 Siting of the Tap:

- (i) The aerial photographs show the approximate location of the tap. The exact location is chosen by the community itself following a meeting, at which project staff have been present to provide advice.
- (ii) Ideally the tap site should be at a central place, or at the intersection of paths. The tap site should not be more than 50 m away from the site as drawn on the aerial photo to avoid a change in pressure due to difference in level.

### 1.11.2 Preparing the Tap Site:

- (i) The Tap Unit is connected to the PVC line, only after the line has been flushed. The tap site is then marked out carefully, ensuring that the apron is higher than the soakaway pit, so that water will drain quickly away.
- (ii) The apron itself should be a circle, 3 m across (10 ft), and keyed into the soil. The edges should be raised above ground level and the apron shaped so that splash water runs away



quickly into the drain and does not remain stagnant upon the apron.

- (iii) The tap unit is placed 0.3-m off centre of the apron, thus giving ample room for the surplus water to collect, and drain to the soakaway.
- (iv) The standpipe is supported with a concrete column, which is keyed into the soil beneath the apron foundation. This column should be cast in a piece of 90 mm diameter pipe, to achieve a good finish. The piece of pipe can be left in position after placing of concrete, to assist in prevention of cracking in the concrete.
- (v) Tap aprons are constructed by RWO's, not by local builders.
- (vi) Rocks for apron foundation are preferable to bricks, as they are more readily available. If no rocks are available then bricks can be used, but only after careful checking of their quality.
- (vii) A large flat stone is placed below the tap, to support the buckets and to receive the impact of the water. It is important that the stone is hard, and of good quality, and that no cement is smeared over the top of it.
- (viii) The drainage channel must be 0.3 m (1 ft) wide and 3 m (10 ft) long. The edges should be raised above ground level, and it should slope so that water runs quickly into the soakaway pit.
- (ix) Both the drain and the apron should be tiled with stones or broken bricks before plastering.

- (x) The Soakaway pit should be a circle of 2 m (6 ft) diameter and dug 2 m deep. The earth from the pit, should be heaped around the top of it forming a ridge, which will protect the pit from surface water. The pit should initially be filled with large stones, of up to 0.5 m diameter, with smaller ones of 0.1 m diameter near the top.
- (xi) Clean river sand should be collected and left at the site.
- (xii) When the village has prepared all this, the village tap check sheet should be completed, and handed to the supervisor.
- (xiii) The Supervisor will then issue three bags of cement.

### 1.11.3 Plastering the Apron and Drainage Channel

The RWO should undertake this task with great care, as the standard of finish achieved on the Tap Aprons, will reflect on the Project as a whole. The Tap is the final stage after months of hard work, and a poor job here will spoil all that has gone before.

Particular care should be taken of the standard materials used. The sand should not be dirty, and the mix should be even. The following steps must be undertaken carefully, in order to achieve the the best possible result.

- (i) Mix five buckets of clean river sand, with one one bucket of cement until a uniform colour is achieved.
- (ii) Add water, gradually mixing all the time until the right consistency is reached, (like nsima).

- (iii) Spread this mixture over the tiles, forcing the mixture down into the voids between the stones. Do not only spread it over the top. Ensure that the stones are well laid having only small gaps between them. This process should be repeated twice more.
- (iv) Level out with a piece of timber, until a fairly even surface is achieved, although not too smooth, as otherwise the final "Skim" will not take too well.
- (v) Mix the remaining cement mixture with water in a bucket to the consistency of thin mpala, and pour this mixture onto the apron. Spread it evenly with a trowel to give the apron its final Skim. The end result should be a "Polish" effect.
- (vi) The flat stone below the tap should be plastered into position, but not covered with cement.
- (vii) The plastered apron should be covered with banana leaves for three days, to allow the cement to harden, before the apron is used.

#### 1.11.4 Issuing a Tap:

- (i) Before a tap is issued, all the points on the village tap check sheet should be filled in and checked.
- (ii) A village meeting should be called for the fitting of the tap, and the official opening.

At this meeting the letter for issuing taps should be read to the people, explaining points as necessary.

Give two or three extra copies of the letter to the leaders.

(iii) Fit the Tap, and give one spare washer to the headman.

(iv) Measure the Flow ~~from~~ the Tap by noting the time taken to fill a 20 litre (five gallon) bucket. Record this flow rate on the Tap Check Sheet.

1.11.5 Malangizo a Madzi a M'mipopi:

(Owerenga akhale m'modzi wa Anthu ozungulira Mpoke)

- (i) Malo onse ozungulira mpope ayenera kukhala osamalidwa bwino ndipo akhale ouma.
- (ii) Dzenje lolandilira madzi otayira lidzazidwe nd miyala. Madzi asaonekere. Ngati madzi sakulowa pansu pa miyalayo, chotsani miyalayo ndikukupa madzi onse. Kenaka ikani miyalayo mdzenjemo. Muyenera kutero kuopetsa udzudzu umene umapereka matenda a malungo.
- (iii) Pa nyengo ya mvula, konzani nthumbira yaikulu ndi yolimba mozungulira dzenje lija kuletsa madzi a mvula kuti asalowe.
- (iv) Ngati sementi ya pa mpope ing'ambika, anthu onse ozungulira mpopiwo asonkherane ndalama kuti akonze sementiyo mwansanga.
- (v) Ndi chosaloledwa kusamba ndi kuchapa zobvala, miphika, mbale ndi magalimoto pafupi ndi mpope wa madzi. Kutsuka ndowa ndimichenga kudzichitikirira ku nyumba osati pafupi ndi chitsime, chifukwa michenga pen phulusa lotsukilalo lingatseke dzenje lija ndi kulidzazitsa mwamsanga.
- (vi) Ngati madzi anu achuluka kwambiri mu ndowa kapena mumtsuko, apunguliridwe mu dzenje bwino-bwino. Osatayiraponse-ponse mozungulira pa chitsime.
- (vii) M'nyumba, ndowa kapena mitsuko ya madzi yizikhala yobvindikiridwa ndi yosamala kuti ntchenche ndi zirombo za matenda zisalowemo.
- (viii) Anthu odwala matenda opatsana, monga mphere, asafike ndi kugwira mpopi wa madzi kuopa kuti angafalitse matenda.

- (ix) Makapu ndi zikho zomwera zidzitsukidwa bwino pofuna kumwera madzi.
- (x) Tiyenera kugwiritsa ntchito madzi a m'mipope posamba, kuchapa zobvala ndiponso zofunda kuti tilewe matenda a maso, ndiponso a mphere.

#### 1.11.5 Tap Opening Ceremony:

The following is a guideline for efficient use of the tap site by the local people, and should be read in either English or Chichewa at every tap opening.

- (i) The tap surrounding must be kept clean and dry.
- (ii) The soakaway pit should be filled with stones well up to the top to avoid breeding site for mosquitoes developing. When the pit is clogged, remove all the stones, scoop out the water, and then refill it with stones.
- (iii) When the apron cracks, the people using the tap should contribute money to buy cement for the repairs.
- (iv) In order to avoid storm water collecting in the soakaway, construct a ridge surrounding the pit.
- (v) No one is allowed to take a bath, wash clothes, utensils, pots, pails nor vehicles at the tap site. Washing of such items leads to the clogging of the soakaway.
- (vi) When the pail or pot is overfull, gently remove the surplus water so that it flows into the pit instead of splashing water around the tap site.
- (vii) In order to avoid flies and other disease carriers to contaminate the water, pails or pots should be covered inside the houses.

- (viii) Persons suffering from diseases such as diarrhoea, chicken-pox etc. should not draw water from the tap to avoid spreading of the diseases.
- (ix) Cups should be washed clean before using them for drinking water.
- (x) Avoid using water from the open wells, running streams or pot holes to avoid water-borne diseases.
- (xi) Make maximum use of tap water.



SECTION ON AA

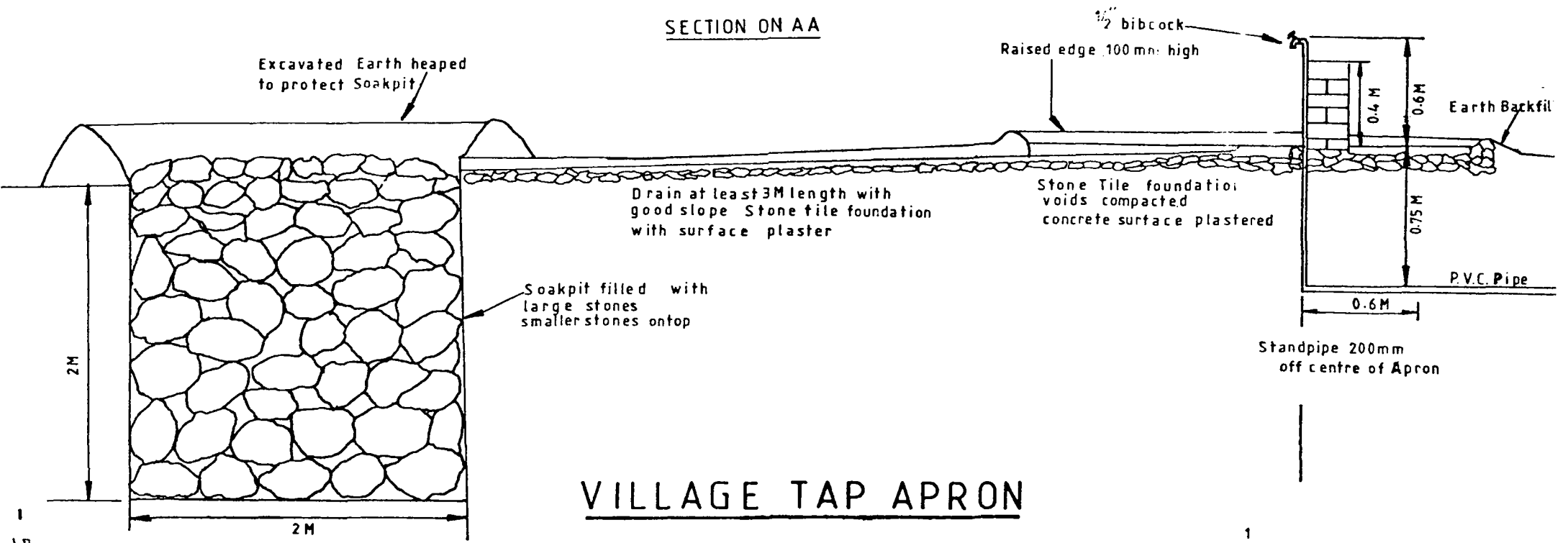

VILLAGE TAP APRON

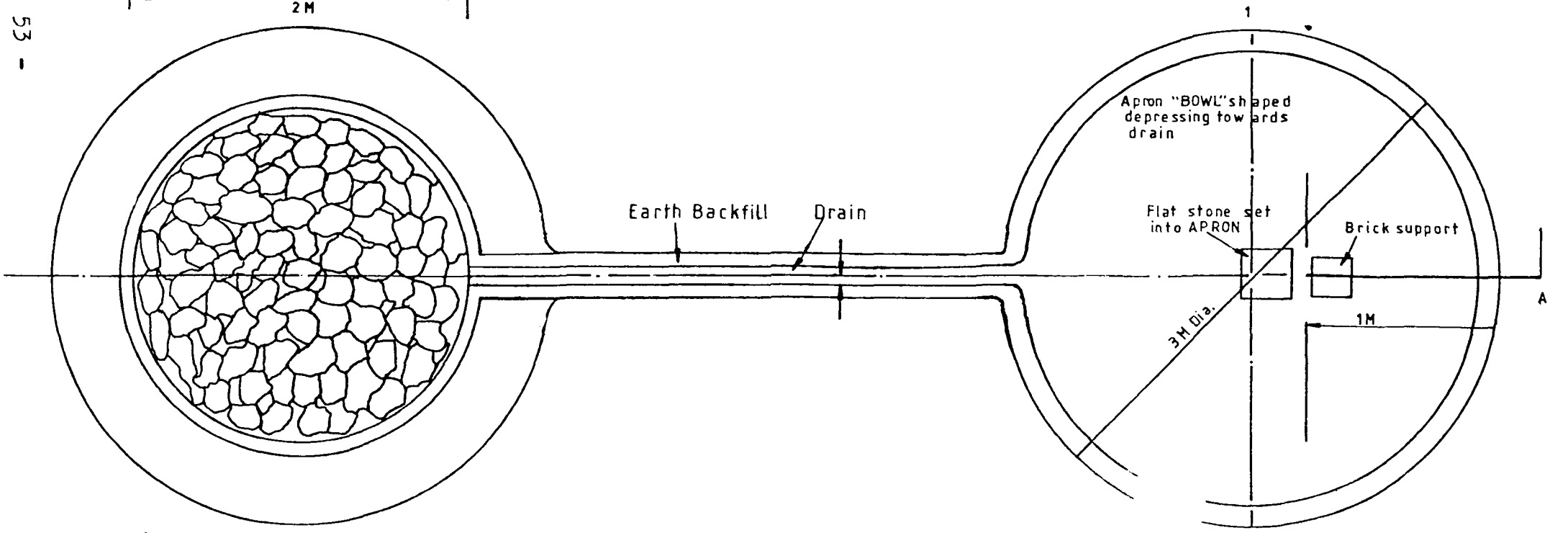

## 1.12 Reinforced Concrete Tanks:

The following types of reinforced concrete tanks are constructed:

1. Screening tanks.
2. Sedimentation tanks.
3. Storage/break pressure tanks.

### 1.12.1 Function of the tanks:

- (i) Screening tanks are to remove leaves, grass and twigs which have entered the pipe system through the inlet holes. The screening function is facilitated by vertically placed screens of 0.5 cm wire. Course sand is also removed, by sedimentation.
- (ii) Sedimentation tanks allow all suspended matter which has not been removed in the screening tank to settle during a retention time of at least two hours. This sediment is removed by regular scouring.
- (iii) Storage/break pressure tanks are to store night flow, and to reduce the pressure head, which has built up in the pipe.  
This prevents the pressure exceeding the working pressure of the PVC pipes, which would result in breakage.

### 1.12.2 Construction:

At present, concrete tanks are built by contractors. Although supervision of tank construction is the direct responsibility of the Project Engineer.

The RWO is an essential link between the builder and the Project Engineer, and he should visit tanks under construction in his area on a routine basis. He should check that the builder has sufficient construction materials sand, cement aggregate, hardcore, and that the work undertaken is of good quality. If problems arise, then the RWO should consult the Supervisor, who can refer the matter to the Project Engineer.

### 1.12.3 Choice and Layout of Tank Site:

The tank is sited by the Project Engineer and cannot be changed by anybody without consultation with the Engineer. Once the tank has been sited, the RWO is responsible for the following:-

(i) Access Road:

Construction materials will have to be delivered by lorry. The access road will have to be cleared and levelled in good time so that materials can be delivered to site. If the lorry cannot reach right up to the tank site, the materials should be dumped as close as possible, and a self help programme organised to carry the materials to the site.

(ii) Tank Site Layout:

In cooperation with the builder a plan should be made of the layout of the tank site, and marked out. This should be done as follows:

- \* Clear the tank site surroundings.
- \* mark out the excavation diameter (see table) and add 5 m to this diameter as reserve area to heap excavated soil.

- \* Choose sites to dump construction materials such as Hardcore, Aggregate and Sand. These should be in a position from which they can easily be moved to the mixing slab.
- \* Choose a suitable place for the mixing slab, the concrete mixer and the tap, preferably in between the tank, the aggregate and the sand.
- \* In case the tank is located on a slope, arrange to dig a RAIN CATCH, uphill of the tank, to prevent rainwater washing construction materials into the excavated tank site.
- \* Choose a site for builders houses, cement store and materials store.

#### 1.12.4 Excavation:

- (i) Arrange a self help programme for excavation.
- (ii) Dig 1.20 m minimum depth. Do not remove large rocks that would be in the foundation anyway. The bottom must be as level as possible.
- (iii) Prepare a number of pointed sticks or pieces of reinforcement wire about 30 cm long, ready for levelling of the tank base by the Engineer.

#### 1.12.5 Quality of Construction Materials:

The RWO is responsible for the quality, and collection, of foundation stones and sand. Programmes for collection should be made well in advance of construction, to allow for proper planning of transport, and should be made during the dry season, to avoid lorries getting stuck on bad roads or river beds.

(i) Foundation stones:

Foundation stones must be of excellent quality. A simple test to find out the suitability of stones is by throwing some sample stones onto others. If the stones break they are useless and better ones will have to be found.

If good stones are not found within walking distance from the tank, a programme should be made to collect stones, and heap them near a road. When enough stones are collected, the RWO asks the supervisor to provide him with a lorry, to carry the stones to the tank site.

When the lorry comes it is the responsibility of the RWO to have enough self help people ready for loading, and off-loading.

(ii) Sand

Sand has to be dug from a nearby river, and is used for concrete. It must be clean and well graded, containing large, medium and small particles. Very fine sand is not suitable.

To ensure that sand is clean it must be dug from within the river, where it is permanently washed.

It is also important for good quality concrete that sand is well graded. A simple grading test in the fields is to rub a small amount of the sand between the thumb and forefingers. If a "crunching" is felt then the sand is suitable. If it is very fine, and moves freely, it must be rejected.

After having found good quality sand a programme is made for self help people to dig the sand from within the river. Before taking the sand out from the river it should be washed by gently throwing it up on the shovel without losing it. After washing, the sand should be heaped outside the river at a place where the lorry can reach without any danger of getting stuck. When sufficient sand is heaped outside the river (for quantities see table on tank construction) the Supervisor is asked to send transport. Make sure that a self-help programme is made for loading, and off-loading the lorry when it arrives.

(iii) Aggregate:

The aggregate, or chipped stone is also to be stocked at the tank site by the RWO. Again quality is an important factor, and the RWO should check to see that it is maintained. The stone which will be broken to form the aggregate should be hard, with no signs of the surface "flaking", or being easily chipped away. Stones which flake, or which are easily chipped should be rejected. The RWO should carefully monitor the size of the aggregate produced as it is being broken, and should check samples from each pile produced.

The maximum size allowed is 20 mm ( $\frac{3}{4}$ " ), and all pieces larger than this should be rejected.

1.12.6 Quality of concrete:

Making concrete is easy, but making good quality concrete definitely is not.

The ultimate strength of concrete is determined by

- \* the quality of the components,
- \* the mixture of the components.
- \* the mixing of the components.
- \* the compaction of the mixture.

(i) Quality of components

The sand should be clean and well graded, the aggregate of the correct size, and the water free from dirt.

(ii) Mixture

An example of a concrete mixture description is 3:2:1, meaning three mixing portions of chipped stone mixed with two equal portions of sand and one equal portion of cement. The size of one portion can be a shovel or bucket. The quantities should always be measured accurately according to the specifications.

It is a common fault to use too much water in concrete, as it makes mixing and placing easier. However it greatly reduces the strength of the concrete. The water content should be about half a bucket to every bucket of cement. Too much water shows when water runs off the concrete before compaction. Too little water also reduces strength, but not so much as too much water does.

(iii) Mixing:

The stone, sand and cement should be thoroughly mixed, whilst still dry, until the colour is uniform. Water should then be added, and mixing takes place again until the colour is uniform. Mixing is either done by hand, or by concrete mixer.

(iv) Compaction:

After pouring the concrete it must be compacted properly to make a tight mixture. Not enough ramming will leave air in the mixture, and too much ramming will separate the components, both resulting in a weak concrete.

Compaction can be done manually (ramming) or by machine, with a vibrator and poker.

The importance of the above points has been clearly illustrated in the field, where tanks have cracked after settling, because the slab wasn't properly compacted. Leaks too have been found, where the aggregate used was too large, or the walls not properly vibrated.

1.12.7 Supervision of Construction:

When a RWO is given responsibility for a tank on his line, then he should check on progress made every day.

This allows him an opportunity to check on the technique of the builder, to see that he is making the concrete in the correct way, and that he is compacting it properly.



It also gives him a chance to estimate when a further delivery of cement will be needed, or extra fuel for the mixer and vibrator. In this way he can order transport through the Supervisor well in advance, and thus ensure good progress.

#### 1.12.8 Completion of Tanks:

The tanks should be fully completed, and ready for service, before the builder leaves the site. With the following tasks being undertaken by the RWO:

(i) Connections:

The RWO should connect the Inlet, Outlet, Scour and Overflow pipes, as shown in the diagrams. The lengths of steel pipes connecting the various fittings should be measured in advance, to allow time for them to be cut and threaded.

Ventilators should also be fitted at this stage, with all fittings being installed on the same day.

(ii) Overflow Drain:

The overflow pipe from the tank should be layed away from the tank to a distance of at least three metres, and keyed in to a brickwork headwall. The headwall, which should be constructed by the builder, will prevent overflow water from cutting back and undermining the tank foundations.

The scour pipe can also be keyed in to the same headwall as the overflow, if it is convenient.

(iii) Flushing:

All tanks should be flushed, with local people assisting to sweep the inside of the tank where debris has collected during building.

Whilst this is taking place the RWO can check all fittings for leaks, before backfilling takes place.

(iv) Backfilling:

To counteract the force of water pushing against the inside wall of the tank, backfilling to a depth of at least 1.2 m should take place. This will also help to offset any poor workmanship, or use of poor materials which has gone unnoticed. Backfilling should also take place around the headwall, and valve protection box.

## REINFORCED CONCRETE TANK INLET CONNECTIONS

AC AND P.V.C. CONNECTION FOR 90mm AND ABOVE

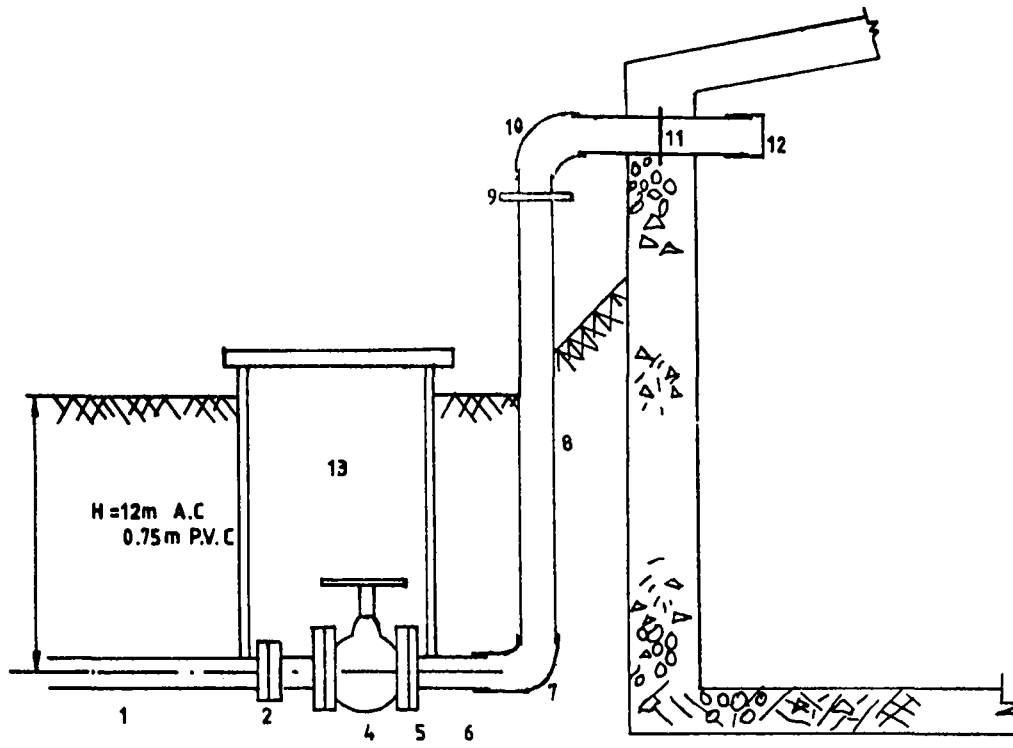

1. A.C. OR P.V.C. PIPE
2. GIBAULT JOINT
3. FLANGE ADAPTOR
4. SLUICE VALVE
5. FLANGE
6. CONNECTING STEEL PIPE
7. ELBOW 90° F/F

8. INLET STAND PIPE
9. FLANGES TO DISCONNECT INLET
10. BEND 90° F/M
11. PUDDLE FLANGE
12. BALL VALVE
13. PROTECTION AND OPERATION BOX.

## P. V.C. CONNECTIONS FOR 75 mm & BELOW

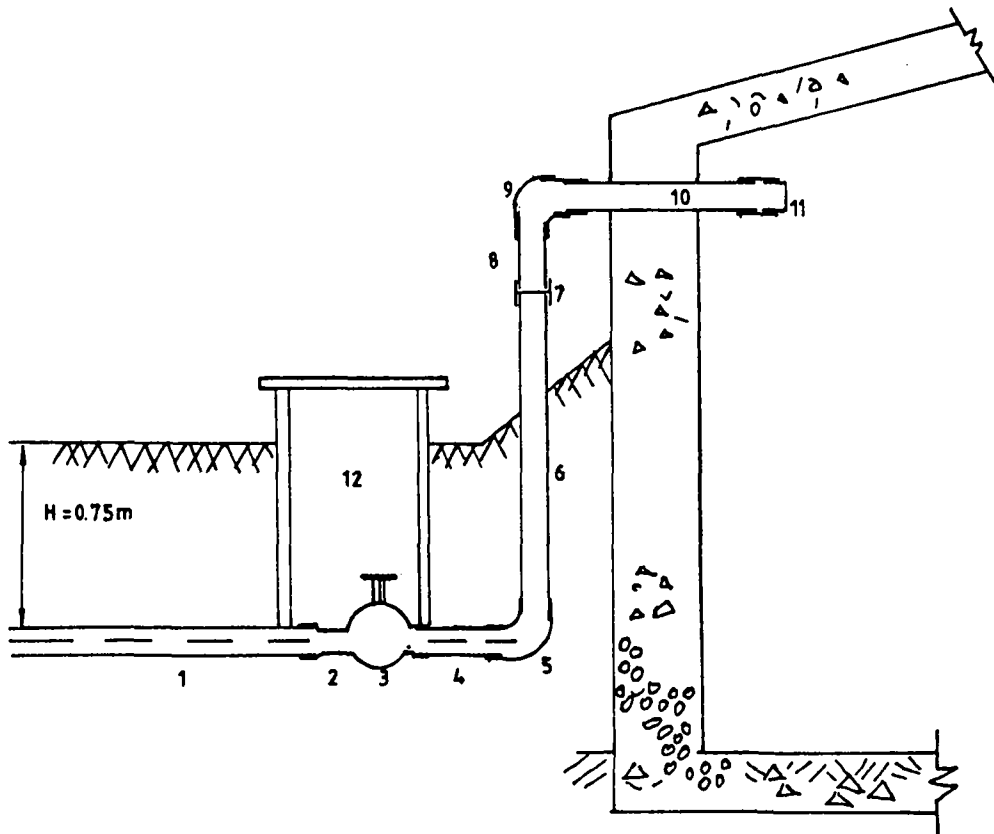

- 1 P.V.C PIPE
- 2 ADAPTOR F/M
- 3 GATE VALVE
- 4 STEEL PIPE
- 5 ELBOW 90° F/F
- 6 STAND PIPE

- 7 UNION F/F
- 8 STEEL PIPE
- 9 ELBOW 90° F/F
- 10 PUDDLE FLANGE
- 11 BALL VALVE
- 12 PROTECTION AND OPERATION BOX.

# REINFORCED CONCRETE TANK OUTLET CONNECTIONS

A C AND P V C CONNECTIONS FOR 90°mm AND ABOVE

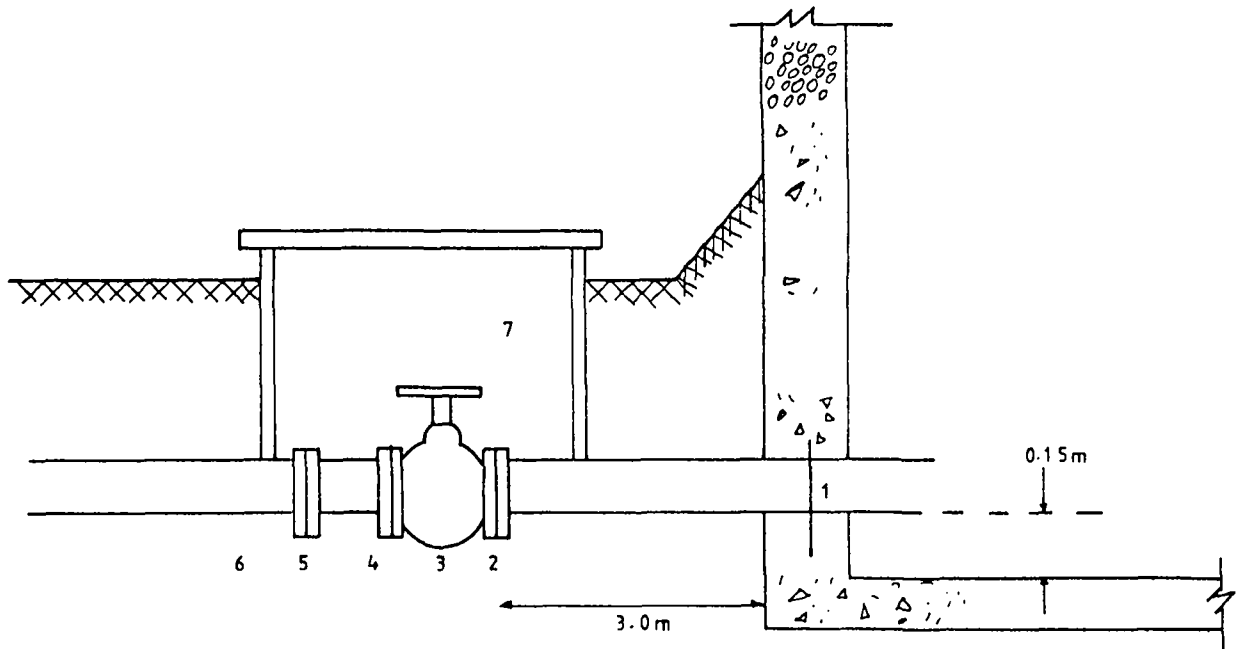

- |                  |                                 |
|------------------|---------------------------------|
| 1. PUDDLE FLANGE | 4. FLANGE ADAPTOR               |
| 2. FLANGE        | 5. GIBAULT JOINT                |
| 3. SLUICE        | 6. A.C. PIPE                    |
|                  | 7. PROTECTION AND OPERATION BOX |

## P V C CONNECTION FOR 75mm AND BELOW

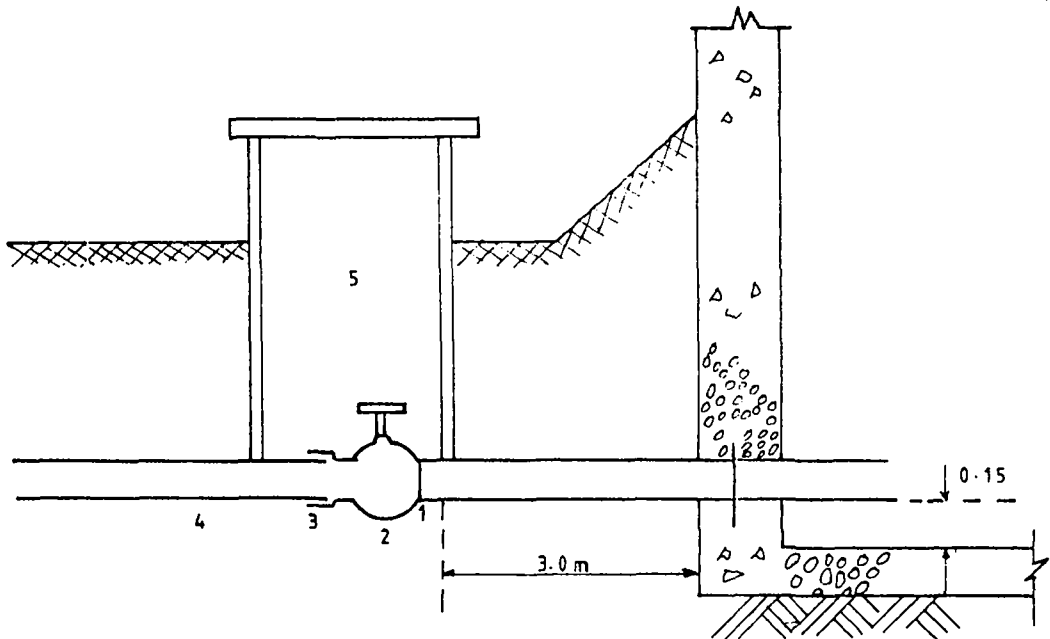

- |                                 |                |
|---------------------------------|----------------|
| 1. FLANGE ADAPTOR               | 2. GATE VALVE  |
| 3. P.V.C. ADAPTOR F/M           | 4. P.V.C. PIPE |
| 5. PROTECTION AND OPERATION BOX |                |

RWO Check List for Tank Construction

Project: ..... Builder:.....  
Operator: ..... Tank:.....  
Date:.....

Preparation for Construction:

Activity	Date Completed
Access Road to Tank	
Plan of tank site Layout	
Stocking, Sand, Aggregate, Hardcore	
Storage facility for cement	
Tap connected	
Rain Catch(if required)	

Delivery of Construction Materials

Item	Quantity	Date Delivered
Reinforcing Rods		
Tying Wire		
Bricks		
Puddle Flanges		
Ladder Rungs		
Overflow fittings		
Control valves		
Ball valves		
Manhole covers		
Locks		
Ventilators		
Valve Protectors		

Rural Water Projects : Tank Construction

Builders' Checklist

Project:..... Builder:.....  
Operator:..... Tank:.....  
Date:.....

Dimensions

Volume: ..... Excavation Diameter:.....  
Inlet size:..... External Wall Diameter....  
Outlet Size:..... N<sup>o</sup> of Pillars:.....  
Scour Size:..... N<sup>o</sup> of Manaholes:.....  
Overflow Size:..... N<sup>o</sup> of Ventilators:.....

Tank Layout:

Reinforcement Detail

Sketch Plan

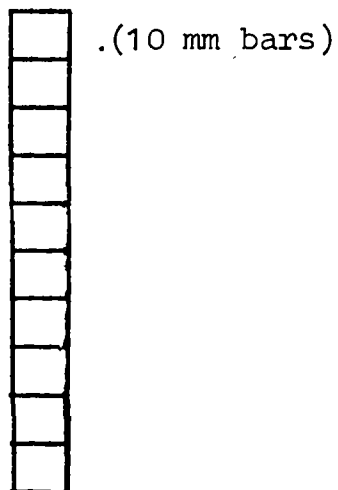

## REINFORCED CONCRETE TANK QUANTITIES

(All tanks are 2m high cast in 10 layers of 0.2m each)

	TANK SIZE (gallons)	EXCAVATION DIAMETER (feet)	INTERNAL DIAMETER (feet)	HARDCORE FOUNDATION (yrd <sup>3</sup> )	RIVER SAND (yrd <sup>3</sup> )	AGGREGATE (yrd <sup>3</sup> )	CEMENT (50kg bag)	N° OF REINFORCING RODS IN WALLS & DISTRIBUTION/2m LAYER	TOTAL LENGTH REIN- FORCEMENT PER TANK. (feet)	BRICKS	N° OF MANHOLES N° OF VENTILATORS	SHUTTERING FOR WALL		N° OF CLAMPS FOR SHUTTERING	SIZE OF OVERFLOW
												OUTSIDE WALL	INSIDE WALL		
600	9	6	1	2	2½	24	7	111111000	120	—	—	—	—	—	—
3,000	13	10	6	7	10	75	7	111111000	1200	600	1	4 x 8'	4 x 8'	50	2"
6,000	17	14	10	11	16	120	10	222111000	2000	600	1	6 x 8' 1 x 0.5'	5 x 8' 1 x 4'	50	2"
10,000	21	13	14	15	22	160	12	322111000	2900	1,000	2	7 x 8' 1 x 5'	7 x 8' 1 x 0.5'	50	2"
15,000	25	22	19	21	31	220	15	332211000	4,000	1,000	2	9 x 8' 1 x 1.5'	8 x 8' 1 x 5'	50	2"
20,000	29	26	25	26	39	260	17	433211000	5300	2,000	3	10 x 8' 1 x 6'	10 x 8' 1 x 2'	100	2"
30,000	35	32	35	34	51	360	20	443321100	7,200	2,000	3	13 x 8' 1 x 1'	12 x 8' 1 x 5'	100	3'
50,000	45	42	55	50	77	530	26	55443321100	12,000	2,500	4	17 x 8' 1 x 5'	16 x 8' 1 x 4'	100	3'



### 1.13 River and Gully Crossings:

One of the major problems faced on every Project is how to successfully negotiate rivers and gullies, which although peaceful in the dry season, become surging torrents during the rains. A basic guide, covering good codes of practice, is provided here for the RWO, but when a situation arises which is too complicated for the Field Staff, then a solution must be provided by the Project Engineer.

#### 1.13.1 Selection of a Crossing Site:

There are several important points to be considered when selecting the crossing site. Although not all of them will be satisfied at any particular location, a reasoned judgement should be made between a number of alternative sites. The following conditions should be referred to, to assist in making a judgement.

##### (i) Design Location:

The crossing site should not be more than 50 m away from the position indicated in the design, on the aerial photographs and maps.

If a site is selected which is more than this distance away, and higher than the original design, then air-locks may develop, which will block the line.

If a site is selected which is more than 50 m away from the original location, and lower, then the working pressure in the pipes may rise above that allowed, and result in breakages.

If no site can be found, either 50 m upstream or downstream of the position shown in the design, then the Project Engineer should be informed.

He will then make a decision, which could involve alterations to the original design.

(ii) Course of River:

Many rivers tend to change course during the rains, when they will cut out a new path for themselves, and continue along that path in the following dry season. Rivers with banks of sand or soft soil will be most likely to do this.

Information should be obtained from the people living near the river, who will explain how the river behaves during the rains. Mark the places where they say the course of the river has been steady.

Also mark the position of the highest water level during the floods. If the people say that the river carries branches and trees when it is in spate, then for safety, an extra 2m should be added to the highest flood level, and this height marked out.

(iii) Good Foundation:

If the crossing is to require pillars for support, then they should be founded on rock, above the highest level, if possible. Suitable rocks may be hidden under grass or bushes, so a thorough search must be made.

(iv) Width of Crossing:

The width of the crossing should be kept to a minimum. This is usually perpendicular to the flow of the river.

The crossing should be measured over the shortest distance, and this length being reported to the Supervisor and Engineer. A decision on the type of crossing to be used can then be made.

If the crossing is wider than 30m, then it can be measured using a string, and the length of the string measured afterwards.

### 1.13.2 Methods of Crossing:

#### (i) Utilising Existing Structure:

The easiest method of crossing is by bolting the pipes to an existing structure, such as a bridge or drift. The pipe should be placed on the upstream side, to prevent it from being washed away during a flood.

Bridges should be carefully checked beforehand, as it is useless to connect to a bridge which collapses in the first flood.

#### (ii) Pipes laid beneath River Bed

If there is no existing structure available, then the easiest method of crossing is to lay the pipes below the river. Long Makande Dambos, which flood for considerable periods of the year should be avoided if possible, when using this method.

For laying below the river the following points must be observed:-

- \* Pipe buried to at least one metre (3').
- \* River bed permanent, does not scour out.
- \* Piping to be steel.

(iii) Pipes Spanning Across River

If neither of the above methods of crossing is possible, then the pipes will have to cross at a safe height above the river. This is the most difficult method, as it will usually involve constructing support pillars, which will be vulnerable during the floods.

1.13.3 Supported Crossings:

The need to support crossings arises when the span exceeds 12m, which is two pipe lengths. For crossings which are shorter than this, the pipe can support itself, if it is firmly placed into the ground on either side of the gully or river. The pipe will usually be supported by pillars, but where this is not possible a suspended crossing will be needed.

(i) Pillar Supports

The pipeline should be supported with reinforced concrete pillars, which are placed a maximum of 12m (40') apart. The pillars should be founded on rock if possible, which needs to be drilled to a depth of 750 mm, and reinforcement rods firmly grouted in to the holes. These rods will then extend up into the pillar itself.

If a rock foundation is not available, then the pillar should be constructed in a pit dug to a depth of 1.5m. The bottom of the pit should be filled with hardcore, and concrete placed over this to a depth of 100 mm. The pillar can then be constructed on this solid base.

(ii) Suspended Crossings

Suspended crossings are used for single spans of up to 24m, where one pillar only is necessary.

With a pillar on either bank, then a span of 36m can be accommodated. This is very useful where there is no suitable rock along the river bank, on which to found the pillars, or where the river floods during the rains, and a pillar cannot be sited near the river bed. The layout of single and double pillar systems is shown in the diagrams.

The Project Engineer will be responsible for the siting of the pillars and Anchor Blocks, but the RWO must ensure that the builder constructs the concrete foundations properly. When the pillar is completed, then the wires must be tightened to support the weight of the pipes. This is done using the Turn Buckles, and the wires on either side of the pillar must be tightened at the same time, as otherwise "sagging" or "humping" will occur. The tightening continues until the pipeline is in an exactly horizontal position. This should be checked some days later to ensure that no stretching of the support wire has occurred.

(iii) Dambo Pillars

These are constructed as shown in the diagram, and will always be sited by the Project Engineer, following a thorough investigation of alternative routes, as dambos should be avoided if possible.

The drums with the reinforcement welded into them will be manufactured at the Regional Office, as will the pipes with clamps attached.

CABLE CROSSINGS

NOTES MAXIMUM SPANS ARE BASED ON MAX 12m SPAN WITHOUT VERTICLE SUPPORT

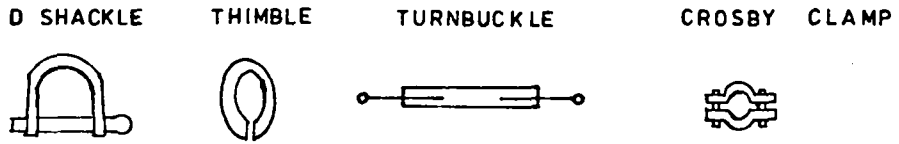
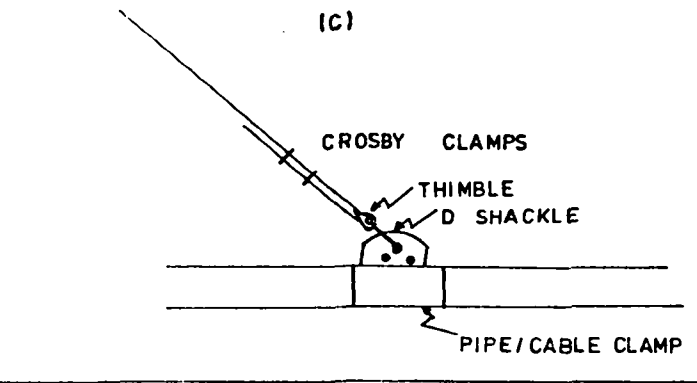
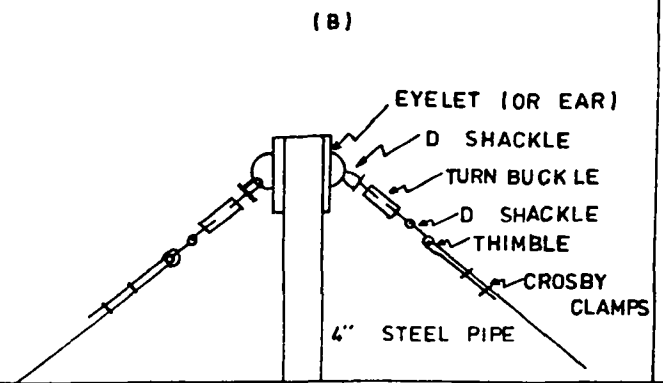
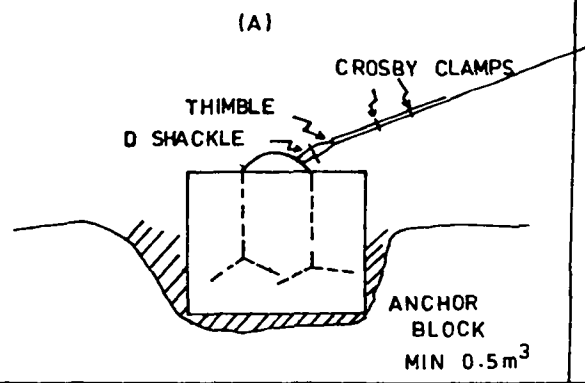
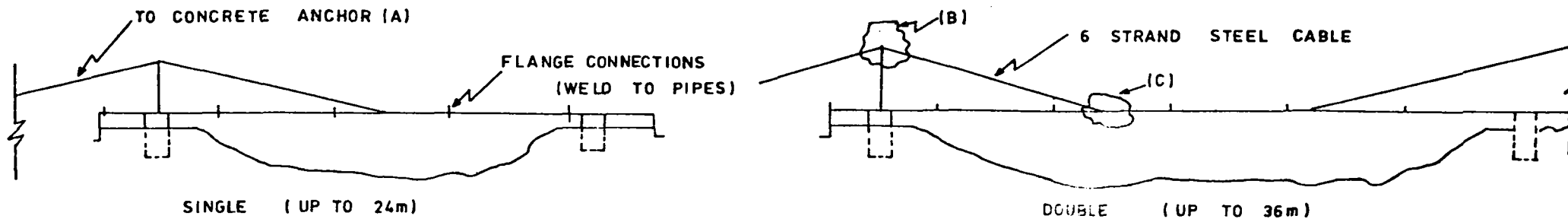

- 47 -

## 1.14 Stores Procedure:

### 1.14.1 Description of Stores:

Stores kept in the water supply schemes can be divided into three groups:

- (i) Fittings for P.V.C., A.C., and steel pipes.
- (ii) Tools: picks, shovels, crowbars, spanners, chain wrenches, monkey wrenches.
- (iii) Consumables: solvent cement, cleaning fluid, cement, rags, soap.

### 1.14.2 Ordering Procedures:

- (i) Make an exhaustive list of all requirements, not forgetting any item, to prevent frustration at the trench, and extra journies being made by Project transport.
- (ii) Order all requirements well in advance to allow the stores officer ample time for preparation, organisation and delivery.
- (iii) Use a stores chit for ordering within the project, and an internal requisition, for ordering through the Stores Supervisor at Headquarters.
- (iv) All tools received should be marked so that they can be identified later. This will help in recovery if they are lost or stolen.
- (v) Cement for the builders is delivered to the site under the supervision of the RWO, and the builder signs for it on delivery.

The stores officer keeps records of the number of bags of cement issued to a RWO. In the case of any irregularity where cement is concerned, the matter will be treated as a criminal offence.

#### 1.14.3 Inventory Sheet:

This is used to keep a record of all returnable items issued to a RWO. A RWO will sign for what he is issued with initially, and he is then responsible for the security of these items.

Anything that is on the inventory sheet, but cannot be accounted for must be reported to the Supervisor.



## 1.15 Transport:

Transport is essential for the success of the Projects. Without transport our work cannot be done properly. However transport is very expensive. A pick-up costs K0.60 per kilometre and a lorry K1.00. Therefore, transport requires very strict control to prevent any unnecessary mileage or misuse. This control is a joint responsibility of all Rural Water Employees, including the RWO.

### 1.15.1 Control of Vehicles

#### (i) Organisation of programmes

To minimise mileage it is important that vehicles are used as efficiently as possible. A RWO should ensure that:-

- \* shortest route is taken
- \* optimal loading is attained
- \* combination of jobs if possible
- \* assistance of self help people.

The programme should include details of the individual trips and loads, such as number and size of pipes, number of bags of cement or reinforcement rods , or quantities of construction materials.

On its way to a job, transport can be used for a number of smaller jobs. For example; if a vehicle has to shift builders from tank A to tank B, it can transport fittings, steel pipes or cement on its way to the tank, and on its way back carry items no longer required.

Whenever the assistance of self-help people is required, for loading and, off loading, a good programme must be ready in advance.

Inform a few villages in case one village does not come because of funeral. Organise a number of jobs for these people whilst waiting for the lorry. It may happen that the lorry is unable to come or is delayed, and this waiting period can be used constructively.

(ii) Quality of Roads

Before a vehicle is requested the RWO must assure himself that the condition of the roads, bridges, drifts and riverbeds is satisfactory. If places are found where the vehicle cannot safely pass, they should be repaired before the vehicle arrives.

(iii) Prevention of Misuse

If a driver misuses a vehicle in any way, the matter should be reported to the Supervisor immediately.

When sent for work, the Supervisor sends a letter with the driver informing the RWO of the programme for which to use the vehicle, and the time that the driver was sent off. The RWO should send a letter back to the Supervisor, informing him of the duties he undertook with the vehicle, and the time he sent the vehicle back to the office. This system is meant to provide a close check on the driver, and a close liaison between the Supervisor and the RWO.

(iv) Application for transport

Transport is limited and cannot come at any moment. It is important for the progress of the job that the transport programme is planned, and applied for well in advance, to give the Supervisor ample time for organisation. When applying for transport details should be given about the different jobs to be undertaken, along with an estimate of the number of trips required.

1.15.2 Loading and Off-Loading:

It is during loading and off-loading, that most damage is caused to the pipes and fittings. It is therefore essential to load carefully, in the correct manner, and to treat the off-loading with the same respect. This will contribute to the efficient, and economic use of the transport, as do the following points to be considered.

(i) Optimal Loading

Optimal use should be made of vehicle capacity, with vehicles being neither overloaded, nor underloaded. The tables give the ideal loading conditions for each type of vehicle, with each different load.

(ii) Off-Loading Sites

The sites for off-loading the pipes should be established in advance, with the drivers and local people being informed.

For A.C. pipes it is suggested that they are dumped along the trench, in groups of 25, at 100 m intervals. This reduces the distances which they will have to be carried, and therefore the possibility of breakage.

For P.V.C. pipes it is recommended that they are dumped along the trench in groups of 100, at 600 m intervals. However it must be remembered that P.V.C. pipes must be placed in the shade, as sunlight causes damage. They must also be stacked properly with heads alternating, as they may wait for a long time before laying.

(iii) Instruction of Local People

The local people should be instructed as to the techniques used in loading and off-loading, and corrected if they are performing the tasks wrongly.

It is essential to impress upon them at this stage the need for Care when dealing with all matters relating to water supply. If this attitude is established at an early stage, then it will be very helpful later on. They should be told that all breakages will result in shortage, and that the pipes belong to them.

If they are not given clear instructions, then chaos will occur. This could result not only in damage to the pipes, but also to personal injury, therefore issue clear instructions, before loading or off-loading begins.

1.15.3 Relationship with Drivers:

The relationship between the RWO and the drivers engaged at the Project should be friendly and respectful. Poor relations will result in lower standards of work.

LOADING LIMITS FOR P.V.C.PIPING-7 TON LORRY WITH PIPEFRAME

Pipe size (mm)	Diameter of Head (mm)	Number of pipes per row	No.of Layers	Max.No. of pipes	Total weight (kg)
12	15	153	120	18,360	6,590
16	19	115	105	12,075	5,800
20	23	100	91	9,100	7,000
25	28	82	71	5,822	7,000
32	36	63	58	3,654	6,200
40	45	51	47	2,397	5,700
50	57	40	36	1,440	4,700
63	78	29	27	783	4,200
75	90	25	23	575	4,600
90	110	20	19	380	3,600
110	130	17	16	272	4,400
125	145	15	14	210	4,600
140	170	13	12	156	4,200
160	210	11	10	110	3,800

NOTE: Stacking should be done in neat horizontal layers, without heads resting on top of each other. Where larger diameter pipes are loaded, smaller ones should be placed inside in a "nesting" system.

### Loading Capacities - Construction Materials

Item	Unit	5 Ton Flat	7 Ton Flat SWB 7 Ton Tipper	7 Ton LWB
Cement	50 kg pt.	100	140	130
Aggregate	Cu. Yd	4½	6	6
Sand	Cu. Yd	4½	6	6
Reinforcing Bar	Length	650	920	850
10 mm.	Feet	26,000	37,000	34,000
Reinforcing Bar	Length	450	620	600
12 mm.	Feet	18,000	25,000	24,000
Bricks	No.	1,500	2,000	2,000

### Example of Calculation of number of Lorry Trips

Collection of sand for a 20,000 gallons tank, using a 7 ton tipper.

From the tank quantities table, on page 68, it is seen that 26 cu. yards are needed.

From the above table it is seen that the 7 ton lorry can take 6 cu. yards per trip.

The number of trips is calculated by dividing the quantity needed by the loading capacity of the lorry.

$$26 \div 6 = 4\frac{1}{3}$$

Therefore 5 trips will be needed.

## 2. COMMUNITY PARTICIPATION AND USER EDUCATION:

### 2.1 Introduction:

The Rural Piped Water Supplies provide good, safe water, in adequate amounts, to rural communities, in order to minimise the adverse health effects of water related diseases in the community.

The Rural Piped Water Supplies are requested by the communities, which consequently commit themselves to contribute all the unskilled labour needed during the construction of the supply. They are also involved as much as possible in the maintenance of the supply.

The government assists the communities with:-

- \* expert advise;
- \* material inputs, pipes, fittings and other construction materials;
- \* transport when required;

Apart from the technical construction, and maintenance, an important aspect of the expert input, is on community participation and user education. The objectives of community participation and user education can briefly be summarized as follows:-

- (i) To make maximum use of the community for construction and maintenance, by actively involving it, and aiming to maximise care, understanding, and pride in the project by one community.
- (ii) To maximise the potential benefits of the improved water supply through intensive user education.

## 2.2 Community Participation:

### 2.2.1 Reasons for Community Participation:

Some community members, and even some leaders may look at their contribution towards the construction and the maintenance, as a sort of punishment. This may badly influence the enthusiasm for self help. It is good to discuss the importance of and the reasons for, self help and community participation, with the community members. Some of the reasons for community participation are:-

- (i) As the community applies for the Rural Piped Water Supply, the community really wants the improved water supply. The community regards good water supply as one of its major problems. A free gift is not always appreciated, but a request for an improvement expresses the real need for it.
- (ii) Because of the self-help participation by the community, and large numbers in which they attend, more can be done in a short space of time. With paid labour a small number can be employed, and few places can be worked at any one time.
- (iii) Because of the contribution of self help, the cost for construction is lower by approximately 25%, this "saving" can be used to buy materials for other supplies. Thus more people can be served.
- (iv) Because of the contribution of the communities during maintenance, the cost of maintenance is low. This enables the government to provide



the water free of charge. If high transport and personnel costs had to be paid, to maintain the supplies, the water would have to be charged for, as happens in the Urban supplies.

- (v) By training repair teams, and committees, responsible for the maintenance of the supplies, members of the communities get trained in new skills, and will be proud to be able to help themselves. Rather than depending on a so called expert, from outside the community.
- (vi) Because of the community care for the supply, vandalism, misuse and abuse are kept to a minimum, which lengthens the lifespan of the supply. The experience in many countries, where communities are not involved, is that water supplies only last for a short time, because the people use the water supply carelessly, and spoil it very quickly.
- (vii) Because of the close involvement of the community, the fruits of its hard work will be appreciated more, which will enable the users to benefit more by improved health and hygiene. The consumers will be more willing to adopt improved methods and practises of hygiene, thus giving better results in health education efforts.
- (viii) It is important, that the communities in the rural areas, see that they can solve their problems, by tackling them communally. A successful rural piped water supply, may encourage the community to undertake another development effort, in a communal way.

### 2.3 The Responsibilities of the Rural Water Operator (RWO)

The RWO assists the communities in the construction and maintenance of their piped water supply. He is trained in:-

- \* the techniques for proper installation and maintenance;
- \* organisational skills to make good and efficient use of self help labour;
- \* skills in community participation techniques and community encouragement techniques;
- \* skills in user education and training of community members for special responsibilities.

The community sees the RWO as the EXPERT in all the above skills, because of his training, and experience. It expects him to advise them clearly and instruct them with confidence. Only when the RWO does not respect the community, or members of committees, in behaviour or speech, or when the community senses that the RWO lacks the knowledge, or confidence to do his job properly, will the community reject the RWO. It is of vital importance for the success of the job, that the RWO pays adequate respect to the community, and its leadership. He must be well informed, and confident, about the technical, and educational job he has to do.

To assist the RWO with his job the Field Handbook is a useful tool, which can be consulted before any job is undertaken. Thus ensuring that the RWO is fully prepared for the task, and does not make any mistakes.

### 2.4 The responsibilities of the community

The rural piped water supply is the property of the rural community it serves. The community is responsible to provide all the unskilled labour during construction. To maintain the completed supply, the community

is responsible for the maintenance and repair jobs, and the proper care of the supply. This includes the prevention, and, if necessary, punishment for, misuse, abuse or vandalism.

It is up to the community to establish regulations on community participation. The community can decide who will participate in self-help, and who may be exempted (the old, sick and handicapped, or, as common in the North, the exemption of females from trench digging).

The communities elect representatives from within to function as committees, which liaise with the RWO. Their main task is the efficient and proper organisation of the community contribution to any activity, in connection with the rural piped water supply. Committee members are elected at Public Meetings and not appointed by influential leaders.

It is also the community which decides on the final location of a tap site during a Public Meeting. This is very important because it ensures that no private interest corrupts the selection of the location e.g. a village headman who instructs the RWO to construct the tap near his house or a businessman offering the RWO money for the tap to be constructed near his dwelling.

It is very important to keep the community well informed of the proceedings, and problems of the rural piped water supply. Secrecy surrounding any issue, concerning the rural piped water supply, will lead to unproductive attitudes and practises, in the communities, and thus do a lot of harm to the supply.

## 2.5 The responsibilities of the Committees

The Committees are responsible for the proper organisation of self help labour, and the equal distribution of labour over the whole community. Also for the care and maintenance of the supply, and for repairs to the supply. The committees of local people are publicly elected, and cooperate closely with the RWO to ensure that the job is done properly, and quickly, and that no friction develops within community. To carry out their tasks properly committee members are trained by the RWO. This includes training in user education, for which the committee members are the primary instructors.

The water committees work at various levels:

- \* village level, the village committee;
- \* branch level, the branch committee;
- \* project level, the main committee.

### 2.5.1 The Village Committee:

The village committees are concerned with the organisation of any activity at village level. In the South these committees are often the "messengers" for the village headman, who inform the community members when to go for work. It is good to extend the duties of the members of these committees to include more responsibilities such as user education, supervision of care for the supply, and maintenance. However, these extra responsibilities can only be introduced after the approval of the village headman, who often wishes to keep the overall control.

### 2.5.2 The Branch Committee

The branch committees are concerned with problems

in their area of attendance and organisation. They are called upon, when the RWO has failed to solve the problem with the village committee, or village headman.

Both the village committee, and the branch committee could overlap with other development activities, such as health extension, and rural access roads. It is advisable not to have separate committees in the village, for health and village development, which may only lead to rivalry and competition, rather than cooperation for the good of the community.

### 2.5.3 The Main Committee:

The main committee deals with problems at project level, which cannot be solved by the village committee, or the branch committee, and which affect the whole supply. Often the Supervisor will contact main committees, rather than the RWO.

### 2.6 Contact between RWO and Committees:

Normally the committees organise the self-help labour themselves. The RWO maintains contact with the committees to discuss the best possible method of organisation, and distribution of the work over the community. However, whenever problems arise within the communities, or the water committees, which hamper the progress of work, the RWO becomes involved as an advisor, to help analyse and solve the problems. He can often analyse the nature of the problem by drawing upon his experience, and advise on the best possible solution. At this juncture, it is important to note that the RWO contacts the committees to discuss the organisation of work, but does not have any authority over the committee, or the community. A RWO cannot go into the village to tell community members

to go for work, nor can he instruct anybody to do that on his behalf, such as Youth Leaguers, or Young Pioneers. The RWO works through the committees in an advisory capacity. In order to ensure success it is important to follow the correct path when contacting the committees or local leaders.

#### 2.6.1 Paths of Communication:

The paths of communication are different for different areas as is shown in the diagram, with procedures in the Northern Region differing from those in the Southern, and Central Regions.

##### (i) Southern and Central Regions:

Assuming a certain village does not arrive for work. The RWO contacts the village water committee first to discover the reason why. If the reason is that the community is not motivated to go for work, the RWO tries to encourage the committee members, and the community itself by explaining the benefits of the supply once completed. He points out the injustice of one village not participating, when all the others are contributing their share. Next he contacts the village headman, who will send his water committee members into the village, to encourage the people to go for work. If this course of action does not lead to satisfactory results, the WPO contacts the branch committee, and asks the branch committee to discuss the matter with the village headman involved. In addition he may refer the matter to his Supervisor. If the branch committee fails to get a positive response, it will take the matter to the main committee.

If the branch committee is not active itself, the WPO or the supervisor will take the matter to the main committee, which may decide to hold a public meeting in the village concerned. If the main committee fails the matter can be referred to the T.A., the M.P., or to the D.D.C. meeting for the area.

(ii) Northern Region:

If a certain village does not arrive for work in the North, the RWO asks the water committee why. If the committee fails to improve the attendance then the matter is taken to the branch committee. He does not go to the village headman, instead the branch committee will then contact the village committee. If the branch committee fails to solve the problem, the matter is taken to the main committee. Thus the village headmen are not directly involved in matters concerning the water supply.

If the main committee fails to solve a problem is taken to the M.P. or the D.D.C. meeting.

In addition to reporting the community problems to the authorities, it is very useful, and constructive to encourage the communities by explaining the potential benefits of the water supply. It is also helpful to organise a showing of the piped water film, (Chichewa version), within the communities, or for the RWO to organise a visit to a neighbouring, completed, rural piped water supply. Here the committee members, and other interested community members, can appreciate the full effect of a piped water supply.

PATHS OF COMMUNICATION

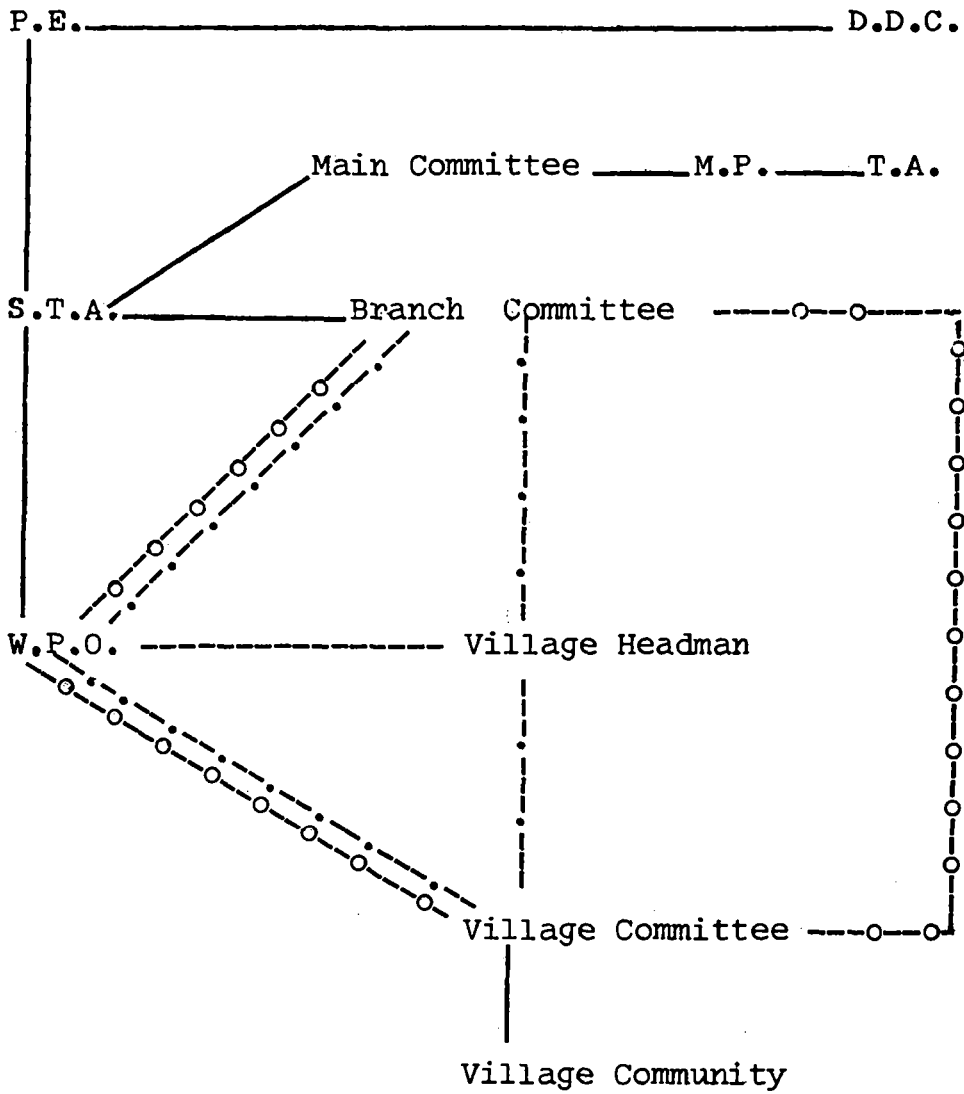

- First path of Communication - South
- .-.-.-.- Second path of Communication- South
- o--o--o-- Communication path - North



### 2.6.2 Difficulties with Committee Members:

Occasionally problems develop with committee members. There have been cases of leaders losing interest, because they discover that there is no direct benefit for them either in the form of a salary, or other privilege. Problems have also arisen because leaders were not trained properly, and therefore made mistakes, which had to be corrected later. To prevent problems of this nature arising, which are basically rooted in misunderstandings, it is important that the RWO trains the committee members thoroughly, and explains their jobs and job conditions well. Leaders should not have false expectations about their job, which may lead them to disappointments. The committee members are working as representatives of their community, to liaise with the RWO, and are not in any way members of the staff of the civil service. Leaders who are not trained properly may be too embarrassed to accept responsibility, fearing that they will make mistakes. An example is a leader who has not been told clearly, to mark out and dig a PVC trench straight. As a result the self-help people may dig a very crooked trench, which proves unfit for laying the PVC pipes in. When asked by the RWO to correct his mistakes, the leader may become embarrassed, and blame the RWO for not instructing him properly, rather than asking the community to correct the alignment of the trench.

Problems of misunderstanding, and false expectations, are best dealt with in an informal way. They often appear during regular supervision visits by the RWO, which underlines the importance of the supervision visits, during which problems can be discussed.

It should be remembered that even during the contact with leaders and committee members, the position of the RWO is as an advisor to the community.

Therefore he must not show any danger or temper in the case of a particular problem, but should remain constructive in seeking a satisfactory solution.

## 2.7. User Education:

### 2.7.1 Introduction:

User education is the instruction of the consumers of the rural piped water supply, with the following objectives:-

- \* To make them understand and practise improved methods of hygiene in order to maximise the benefits of the improved water supply.
- \* To teach what to do in the case of a problem with the water supply; where to report and what to report when the water stops.
- \* To teach the rules and regulations of the water supply to make the users understand the reasons, and give them a feeling of responsibility for the communally owned water supply.

### 2.7.2 Methods of User Education:

User education can be undertaken at arranged Public Meetings. Here a certain problem can be discussed with the entire community. It is more important however to instruct users as the RWO travels through the villages. This informal method gives an opportunity to point out a particular problem to an individual user, a small group of users, or a community, in a spontaneous way which often leads to better results.

(i) Health Education:

On his way home the RWO may find a group of users around a tap. He may stop and start a conversation on the health benefits as experienced by the users. He may ask the users questions such as:

"What are the most important benefits of the improved supply as experienced by the community?"

"Why are these benefits the result of the improved water?"

"Do the users think that they can obtain more benefits?"

"What would they have to do to obtain these additional benefits?"

If the community fails to give correct answers the WPO can give appropriate advice to the users.

(ii) Discussion of Procedures:

Whenever the RWO notices that a tap has stopped giving water, he will ask the users around the tap what the reason is for the breakdown, whether it was reported to the committee, and the repair team, and what action will be taken and when.

When the RWO discovers that the users have not done anything, he teaches them what they should have done. He encourages the community to follow his advice, and returns to the problem spot a few days later, to check on whether the community has followed his advice.

In addition he can leave a Kalata kwa Atsogoleri, and a Kalata ya Madzi kwa Anthu Onse.

(iii) Correct Consumption :

A RWO may find that a tap may only be used for drawing water for certain activities such as drinking and cooking. It is important to find out the reason for this restriction, and if it is a rule which was imposed by the water committee, or any other leader, without real justification. It can be explained to the community that the water is meant to be used for all activities, drinking, cooking, bathing, washing clothes etc.

The RWO can explain that the design for the water supply allows every member of the community to draw six gallons of water per person per day. This is equal to approximately one and a half buckets of water, per person, per day. Thus a family of six is entitled to collect nine buckets of water each day. If the family collects less than nine buckets, it does not consume what it is allowed, and what is recommended to obtain the maximum health benefits. In addition the WPO can hand out a Kalata ya Madzi and a Kalata ya Malangizo a mipope.

(iv) Community participation in Care of Supply

Whenever a RWO notices that a soak away pit is dirty, or full, he should stop and ask the users if they are happy with the state of the soak away pit. After a discussion the RWO can advise the committee members to organise the cleaning of the pit. This can be done while the RWO is on the

spot to ensure that the work is started. The RWO can even encourage the community to start the actual cleaning in his presence.

(v) Misuse and Abuse:

Whenever a RWO finds children playing at the tapsite, or finds women washing clothes or pots on the apron, he stops and asks the users if this is normal practise. When asked the community will most likely disapprove of this misuse and abuse, and will prevent it occurring in the future.

(vi) Vandalism:

When the RWO notices that women turn off the tap by screwing the handle down very tightly, he stops and explains to the users that the bibcock needs gentle operation. He explains that screwing tightly will damage the threads on the spindle, thus damaging the bibcock, which will start leaking, and will need to be replaced with a new one.

(vii) Care and Repair:

When the RWO notices that an apron is cracked, he should point out to the committee and the community the importance of repair, for which cement is required. Leaving repairs to a later date will worsen the situation, and will lead to more costs.

From the above examples it is clear that instruction can be undertaken at any time. Whenever a certain problem is widespread, and is not clearly understood by the leaders, the RWO can ask for a Public Meeting to discuss the issue in detail.

A part from the Public Meeting and the informal method in the communities a third method of user education is by distribution of Kalata. A number of Kalata have been developed and mass printed. It is important to distribute these forms whenever there is a need for them. They are clearly written documents, to which hthe community members can always refer in case of any question or problem.

A sample of the Kalata is included :

- \* Kalata to announce the project.
- \* Kalata kwa Atsogoleri.
- \* Malangizo a mipope.
- \* Kalata ya madzi kwa Anthu onse.
- \* Mafunso kwa Anthu Ofotokoza Mipope

### 2.7.3 Methods of Discussions:

User education can be done in two ways:

- \* by lecturing.
- \* by questioning and then advising.

#### (i) Lecturing:

During Public Meeting the RWO normally has not much opportunity to ask questions. He should be well informed about the problem under discussion and know how to advise the community, and leadership when asked to do so. However, he should realise that he is acting as a adviser to the community, and this must be clear from his behaviour and speech.

(ii) Questioning and Advising:

Before advice can be given about a certain problem, the RWO must be clear about the reasons for the development of the problem. To discover these reasons it is advisable to ask a number of questions, which will give the background to the problem.

When the RWO finds a woman washing her clothes in the river, and immediately starts telling her how bad that is, without allowing her to explain her reasons, the RWO is likely to find later that his instructions have not changed the practises of the woman. However he will have alienated himself from the woman. The WPO should have started by asking that woman why she is washing clothes in the river, the answers would have given him an idea about the nature of the problem, which can consequently be used to lead on to useful advice.

Example of discussion:

RWO : Why are you washing clothes in the river?

Woman 1: Because the tap is plugged.

RWO : Why is the tap plugged?

Woman 1: Because the bibcock was worn out;

or

Because the soak away pit is dirty.

RWO : Please ask the committee members to come.

And the WPO continues the discussion with the committee. This is a problem of maintenance or repair.

RWO : Why are you washing clothes in the river?

Woman 2: Because the leaders do not allow me to use tap water for washing clothes.

- RWO : Please ask the committee to come.  
This is a problem of incorrect consumption.
- RWO : Why are you washing clothes in the river?
- Woman 3: Because I have always done it.
- RWO : Do you know of any dangers when washing clothes in the river?
- Woman 3: No, I don't know.

In this case the WPO can give some health education on the dangers of washing clothes in rivers, or in stagnant pools.

- RWO : Why are you washing clothes in the river?
- Woman 4: Because washing in the river is easier. I have stones for washing on, there is plenty of water which I do not have to carry in buckets to the house. I only have to carry my dirty clothes. And I have the company of my friends.
- RWO : Do you know the dangers of washing in river?
- Woman 4: Yes, I can get bilharzia and other diseases but still, my grandmother also used to come here.

In this case it may be good to organise a Public Meeting discussing the problems of availability of water, and the risk of attracting bilharzia, and other diseases by washing in the river.

#### 2.7.4 Water Related Diseases:

There are many types of water related diseases, which constantly effect the Rural Population. The effect of these diseases can be considerably reduced by the correct use of a good water supply. The diseases can be divided into the following categories:-



(i) Water borne diseases:

These diseases are transmitted when the disease is in water which is drunk by a person who may then become infected.

Examples of water borne diseases are cholera, typhoid, infectious hepatitis, and dysentery. To prevent infection by water borne disease it is important to drink safe water.

(ii) Water washed diseases:

These diseases can be reduced considerably by using more water for washing the body, and by washing the body more frequently. The quality of the water does not need to be very high.

Examples of these diseases are diarrhoeal diseases, infections of the skin, such as scabies, and eye infections. Also infections which are transmitted to a person by parasites, such as lice and fleas.

To prevent infection by water washed diseases it is important to wash the body regularly and with good amounts of water (say a full bucket of 20 litres per person).

(iii) Water based diseases:

These are the diseases transmitted by worms which live in the water, and which enter the human body when it is in contact with infected water.

An example is bilharzia, which is contracted when washing, bathing, or playing in a slow moving river or stagnant pool, which is inhabited by the snails carrying the infective larvae.

To prevent infection by water based diseases the community members should be strongly advised not to use, or enter infected water, in rivers or stagnant pools, but to use tap water for all activities.

(iv) Water related diseases:

These are diseases which are transmitted by insects, in particular mosquitoes, which breed in water, and subsequently transmit malaria. To prevent these diseases, users should be advised to keep the tap surroundings clean and dry. They should also remove stagnant pools of water from the areas surrounding the houses.

2.7.5 Pollution:

Although the tapwater is normally safe and clean, pollution can occur and spoil the quality of the water. Turning it into a health hazard, instead of a health benefit.

Pollution can be introduced to the supply at many points, and great care must be taken to avoid this, especially at the following places:-

(i) At the Intake:

Most intakes of the rural piped water supplies are constructed within protected forest reserves. However, although these intake catchments are formally under the protection of the Forestry, in Mulanje and other places such as Liwonde, the Forestry Department has not been able to prevent encroachment of the forest reserves. In Mulanje people have started cultivating above, and within the catchments of the rural piped water supplies.

This has led to a serious situation, whereby communities of many thousands of people are threatened with pollution of water supply.

It is the task of the RWO, to constantly explain the importance of catchment and intake protection, to the communities, and to point out the dangers of pollution.

Whenever a case of pollution is reported to the RWO, he must immediately report it to his Supervisor. He will report without delay to the Engineer, who will report to the D.C. as the chairman of the D.D.C.

(ii) In the distribution system:

To prevent children and ill wishers interfering with the water inside the tanks, locking devices have now been developed to fit over the manholes. In addition, it is important that the RWO points out the dangers, of pollution of water inside tanks by ill wishers to the community.

Pipes which leak may not only hamper the service of the supply, but may also draw dirt (soil and bacteria) into the system. To prevent cases of pollution by this dirt or bacteria it is essential that the repair teams are aware of the importance of mending a breakage, or leakage, as quickly as possible.

(iii) Pollution between collection and use:

Although water as supplied from the tap may be safe and clean, pollution can occur between the

moment of collecting the water and the time of consumption in the house. This can be to the supply at many points, and great care must be taken to avoid this, especially at the following places:-

- \* A dirty container in which the water is collected.
- \* pails used for washing clothes as well as carrying clean water.
- \* leaves used to stop the water spilling may introduce harmful bacteria to the water.
- \* if pails are left uncovered in the house dust or dirt from animals in the house may pollute the water.
- \* Cups used for drawing water from the pail which are not kept clean may introduce pollution to the water.

It is important to point out the dangers to community members, and advise them of the correct procedures.

#### 2.7.6 Advice to Maximise Health Benefits:

##### (i) Full use of Piped Water Supply

Tap water is safe and clean as supplied from the tap if no encroachment by humans above the intake has taken place. Any other source of water may well be infected by some form of water related disease, and should therefore be abandoned, once a rural piped water supply is available. Users of rural piped water supplies, who will still continue using secondary infected sources for certain activities such as washing clothes, or bathing, may not obtain the benefits potentially available.

(ii) Personal Hygiene:

Some advice for personal hygiene is provided in Malangizo a Mipope. These recommendations are very important and should be followed by all members of the household, including the children. Often the standards of hygiene in children are lower than in adults, which makes children more likely to be infected.

When washing the body just pouring on water is not sufficient. Soap should be used, and if not available a stone to rub the skin.

After attending the chimbudzi, hands should be thoroughly washed every time. Children should be made to use the chimbudzi, rather than using the bush.

(iii) General Hygiene:

Often dysentery is contracted from food which is not hygienically prepared or kept, rather than from the water supply.

Rats and mice are living in the roofs of the houses, and are carriers for fleas and lice, which can easily be transmitted to humans, or to the food. For these reasons it is important to have high standards of hygiene in general, rather than in connection with water only.

(iv) Excreta disposal:

Excretion outside pit latrines is a great danger and can spread many diseases such as worms, and dysentery.

As pit latrines are becoming more common, it is important that they are constructed and used properly or they could themselves prove to be a health hazard. In addition, although a pit latrine may be available, children may still use the bushes. This should be eradicated by proper education of the parents

(V) Outside Influences

Although the hygiene standards within the family may be good, members are exposed to the hygiene standards of their community as well. Water related diseases may not be contacted from within the house, but from contact. With other households or community members, when visiting a friend, a beer hall or a restaurant. The hygiene standards at beer parties are extremely poor. Cups are passed without cleaning from one person to the next. Often these cups are superficially cleaned after the party, to be used again for the next party, sometimes building up a cake of left overs from previous parties inside the cup.

(vi) Summary

To obtain the maximum health benefits of the improved water supply it is important to;

- \* draw water from the tap and use it for all activities related to water, not just for drinking and cooking.
- \* Encourage the users to use more than the present quantity, which is approximately 3 gallon/head/day.

instead of the design consumption of 6 gallons/  
head/day.

- \* Abstain from any contact with infected water sources such as rivers or stagnant water pools.
- \* Maintain good hygiene standards in the house in connection with the water, food, and excreta disposal.
- \* Realise that infection can occur outside the house during visits to friends or beerhalls.
- \* Always use the same clean container for drawing water, which is covered when kept inside the house.

## 2.8. Establishment of Standards:

User education requires examples both of good and of bad practise, to illustrate clearly to the communities the standards which are acceptable.

### 2.8.1 The RWO and his family:

It is obvious that the RWO and his family are closely observed by the community, as regards their standards of hygiene. In particular the wife and the children of the RWO should be exemplary to the community. For these reasons, it is important that the RWO teaches his wife and children first of all, and emphasises the importance of the highest possible standards of hygiene within the family, before he starts teaching the communities.

### 2.8.2 Good tap sites

In Mulanje a competition was encouraged among the communities for the best apron and surrounding. As a result many soak away pits in Muloza are beautifully smeared with dambo sand, many aprons have brooms to keep the aprons and the surrounding clean, and cups to drink from. All aprons are kept in a very good state of repair. In Lichenya fences were built with bamboo around the tapsites with entrances and outlets for the users. Although the fences are mainly decorative, they express a sense of pride in the supply. In Namitambo many aprons are decorated with flowers around the tapsite and the soak away. These expressions of pride are a very good foundation on which to build user education. Taps and tapsites which are not neat, clean or in a good state of repair, can be compared with the good examples. Communities who do not care very much about their hygiene, will be ashamed, when they are publicly told that their tapsite is very bad compared with others. They may then be likely, to improve their hygiene, and state of repair of their apron and tapsite.

### 2.8.3 Influence of Committees:

The reason for low standards of hygiene is often ignorance or negligence. It is the responsibility of the committees to deal with both these factors, by exerting control over the communities which do not observe the correct procedures.

Strong committees which exercise their control properly, can establish improved standards of hygiene, and levels of service, for the whole community.



## 2.9 Maintenance of Service Levels:

It is most important that the RWO emphasises to the consumers that they must report all problems immediately to the committees and repair teams.

There is a real danger that the water supply will fall into disrepair, if problems are not dealt with promptly. Ultimately this could result in the complete collapse of the system. The RWO should explain to the communities that a high level of service can be maintained, if each person contributes to the upkeep of the scheme, by treating it with respect, reporting all problems, and observing the regulations of supply.

## 2.10 Regulations of Supply

The regulations to be observed in order to maintain a high level of service are outlined in the "Kalata". It is important that the RWO continuously reminds the people of the need to exercise proper care for the scheme, and to observe the regulations. This will result in a high level of service being provided for many years.

## KALATA YA MADZI KWA ANTHU ONSE

Tiri ndi madzi abwino a mu mpope chifukwa tinagwira ntchito molimbika pokumba ngalande nthawi zina kumaoneka kuti madzi asiya kutuluka pa tapu yathu, izi zimachitika pa zifukwa zambiri monga:-

- (A) Kusweka kwa paipi.
- (B) kutsuka mu tank (Nkhokwe ya madzi)
- (C) Paipi kugwidwa ndi mpweya ndi zina zotere zambiri.

### 1. Zoyenera kuchita ngati madzi asiya kutuluka pa tapu yathu:

- (a) Tiyenera kuuza atsogoleri a madzi.
- (b) Atsogoleri a madzi mogwirizana ndi anthu onse atsatire ngalande kuti awone ngati pena paipi yasweka.
- (c) Ngati tiona malo osweka aja tiyenera kukonzapo mwansanga.
- (d) Koma ngati titsatira ngalande yathu ndikuona kuti sitinapeze malo osweka, ndi bwino kuona matapu a midzi ina ngati madzi akutuluka. Ngati tiona kuti satuluka tiyenera kudziwa kuti ndi ngalande yayikulu yomwe yabvuta, choncho atsogoleri tidziwitsane za bvutoli kuti titsatire ngalande yayikulu.

Ndi udindo wa munthu aliyense ngati waona kuti pena madzi asweka kudziwitsa atsogoleri oyenera. Izi zimatithandiza kumwa madzi athu nthawi yayitali.

### 2. Ubwino wokhala ndi madzi a mumpope:

- (a) M'malo mokatunga madzi ku mtsinje kutali timatunga madzi a mumpope m'mudzi mwathu momwemo.

- (b) Madzi a mumpope ndi otetezedwa ku matenda omwe tingatenge ku madzi a ku m'tsinje monga kamwazi, likodzo, ndi ena otere. Choncho ngati tigwiritsa ntchito madzi a mumpope pa nchito zathu zonse tidzateteza matenda ambiri ndipo tidzakhala osadwala-dwala.

Malangizo a madzi a mipope:

- (a) Madzi a mipope ndi a ulele ndipo ndi a munthu aliyense.
- (b) Munthu ali yense akhoza kutunga madzi monga momwe angafunire ndikugwiritsa ntchito ili yonse imene angafune, koma zizchitikira ku nyumba osati pampope pomwepo ai.

KALATA YOFOTOKOZA ZA MADZI A MIPOPE KWA ANTHU ONSE

(Yowerengedwa pa msonkhano wa madzi kwa anthu)

1. Malingana ndi pempho la akulu-akulu wokuimirani, tsopano Boma liri lokonzeka kuku thandizani pa ntchito yanu ya madzi a mipope omwe akhale anu.
2. Madzi amipope ndi abwino ndi otetezedwa omwe adzaperekedwa kwa anthu m'magulu.
3. Chifukwa choti madziwa ndi a wanthu onse choncho palibe aliyense amene akuloledwa kugwiritsa ntchito mopitiliza muyezo kapena kukhala ndi tapu yake.
4. Malingana ndi wodziwa za madzi anaganizira kuti munthu aliyense adzigwiritsa ntchito madzi wokwanira 6 gallons pa tsiku imene iri 27 liters kapena ndowa imodzi ndi theka ya 20 liters.
5. Madziwa angagwiritsidwe ntchito pa zonse monga kumwa, kuphikira, kuchapira, kusamba ndi ntchito zina.
6. Madzi ayenera kutungidwa kuchokera pa tapu.
7. Madziwa ndi aulere.
8. Boma lidzakuthandizani pokutumizirani alangizi ndi zinthu zonse monga mapaipe, sementi ndi zina.
9. Wanthu mogwirizana adzagwira ntchito modzithandiza okha mofanana.
10. Ntchitoyi ikadzatha idzaperekedwa kwa anthu kuti azikhonza ndi kusamala okha.
11. Ngati mungasamale madziwa podzikonzera nokha adzakhala nthawi yaitali.

NTCHITO YA MADZI  
KALATA KWA ATSOGLERI ONSI

1. Tsopano madzi afika m'mudzi wanu chifukwa chakuti mwagwira ntchito molimbika. Madziwa ndi a ulele koma chofunika kwambiri ndi kusamalira.

2. Kasamalidwe:

(a) Madzi

Nthawi zonse mukatsegula madzi, muone kuti mwatseka tapu musanachoke pa mpope. Musasiye madzi kungotayika.

(b) Ma Tapu

(i) Pamene mutseka tapu yanu muyenera kutseka mwamtima uli pansu kuti ingaonongeke msanga. Ngati pamene mutseka tapu muona kuti madzi sasiya kutuluka ndiye kuti washala m'kati mwa tapuyo yatha. Choncho ndi bwino kuikamo ina washala mwansanga kuwopa kuti tapu ija ingasweke. Ma washala amapezeka ku likulu la mipope ndipo amapelekedwa mwaulele.

(ii) Ngati tapu yanu yasweka anthu nonse a m'mudzimo muyenera kusonkha ndalama zogulira tapu yatsopano ku likulu la mipope. Mtengo wake ndi K2.00 (1976).

(iii) Malo wozungulira tapu yanu ayenera kusamalidwa bwino. Sitiyenera kutaya madzi paliponse, sitiyeneranso kutsuka chida china chiri chonse monga : ntharo, mbale, zobvala, kusamba ndi zina. Ngati madzi adzadza pa dzenje chotsani miyala yonse ndi kutaya madzi oipa.

Bwezelani miyala yonse kuti tilewe matenda.

(c) Mipope

Ngati aliyense waona kuti m'pope waphulika awauze akulu-akulu amene ali pafupi kuti akatseke madzi pamene pali chotsekera pafupi. Madzi aja atatsekedwa wina mwa atsogoleri kapena Mfumu athamange mwa msanga kukafotokozera a kulikulu la mipope. Akulikulu la mipope adzakupezelani zofunika zonse zokonzera malo osweka aja.

(d) Ngalande

Mzere wa pa ngalande yanu ukhale waukulu ndiponso wosamalidwa bwino nthawi zonse. Munthu ali yense asalime kapena kubzalapo mbeu pa mzerewu. Ngati ngalande yayenda m'munda, mwini mundayo azisamalira mzere uja. Mizere ya m'munda ngati yayenda mopingasa mzere wa pa ngalande, pafunika kuti mizere ya m'munda muja ilimidwe mogunditsa ku mzere wa ngalande. Ngati patsala mpata ndiye kuti madzi othamanga a mvula adzakokolora nthaka ya m'munda ndiponso mzere wa ka ngalande.

(e) Thanki (Nkhokwe ya madzi)

Ndi chinthu chofunika kwambiri kuona kuti pozungulira nkhokwe ya madzi pali polambulidwa nthawi zonse. Ndiponso nkhokwe za madzi zifunika kuchapidwa kawiri kapena kamodzi pa chaka chiri chonse, kuchotsa dothi limene limalowa m'nkhokwe muja.

Kuthokoza:

Ndi mwambo wa a Malawi nthawi zonse kuthokoza pakachitika chinthu cha phindu. Tonse tidziwa kuti madzi ndi moyo wa chinthu cha moyo chiri chonse, kuyambira anthu, nyama

ndi zomela zomwe. Madzi ngati asowa ndiye kuti imfa yamuyandikila aliyense.

Kuno kwathu bvuto la madzi lidalowerela ndithu kotero kuti sitidziwa chimene chidakaoneka patsogolo bvutolo lidakapitirila. Mwa mwai tinadalitsika pakukhala ndi mtsogoleri wathu wa muyaya Ngwazi Dr.H. Kamuzu Banda. Mtsogoleriyu ndi nzeru zake zokonda anthu, anaona bvuto la kuno kwathu losowa madzi. Ndipo iye adapempha abwenzi kuti athandize kuchotsa bvuto lakusowa madzili, Ndithudi, Mtsogoleri wathu alikuthokozedwa mosalekeza. Ndipo Chauta ampatse moyo wautali.

Komanso anthu onse amene anathandiza kuthetsa bvutolo pogwira ntchito ndi manja awo kukumba ngalande, kumanga mipope ndipo kukwilira ngalande zonse mpaka kumwa madzi ali kuthokozedwa. Ndithudi anthu amenewa agwira ntchito yaikulu yothandiza kukweza dziko la Malawi ndiponso awakonzera ana a mtsogolo chinthu chaphindu. Chonde tiyeni kugwirizana kwathu kupitilire patsogolo pa chili chonse tachilandira kapena tachipanga.

MALANGIZO A MIPOPE NDI ZA KASAMALIDWE

KA MADZI A KUMWA

1. Malo a mipope ndi mozungulira monse muyenera kukhala mouma ndi mosamalidwa bwino.
2. Dzenje lolandirira madzi otayila lidzazitsidwe ndi miyala. Mazdi oyima asaoneke. Ndipo ngati madzi sakulowa pansi dzenje liyeretsedwe bwino-bwino kuti zirombo zopatsa matenda zingaswane.
3. Ngati cementi yang'ambika mozungulira mipope anthu apa mudzi umenewo akonzé mwansanga. Zofunika kukonzera zisonkhanitsidwe ndi anthu a mudziwo.
4. Pa nyengo ya mvula, konzani nthumbira yaikulu ndi yolimba mozungulira dzenje lija kuletsa madzi a mvula kuti asalowe.
5. Ndi chosaloredwa kusamba ndi kuchapa zobvala, miphika, mbale ndi magalimoto pafupi ndi pamipope ya madzi. Kutsuka ndowa ndimichenga kudzychitikila kut nyumba osati pafupi ndi chitsime, chifukwa michenga pena phulusa lotsukiralo lingatseke dzenje lija ndi kuli-dzadzitsa mwa msanga.
6. Ngati madzi achuluka kwambiri apunguliridwe mu dzenje bwino-bwino. Osatayira ponse-ponse mozungulira pa chitsime.
7. Ndowa zotengera madzi zikhale zosamala bwino. Madzi adzitsanulidwa mu mtsuko otungira kuchokera mu ndowa osati kutungira mu ndowa ndi kapu kapena chikho kuwopetsa matenda.



8. M'nyumba, ndowa ya madzi ikhale yobvundikiridwa ndi chosamala kuti ntchenche ndi zirombo za matenda zisalowemo.
9. Anthu obvutika ndi matenda opatsana asafike ndi kugwira mipope ya madzi kuopa kuti angafalitse matenda.
10. Makapu ndi zikho zomwera zidzitsukudwa bwino pofuna kumwera madzi.
11. Tiyenera kugwiritsa ntchito madzi a mipope posamba, kuchapa zobvala, ndiponso zofunda kuti tilewe matenda a m'maso, ndiponso mphere.

DEPARTMENT OF LANDS, VALUATION AND WATER - RURAL WATER SUPPLY

BRANCH

MAFUNSO KWA ANTHU OFOTOKOZA (OKONZA)

MIPOPE

Villages:.....Tap Nos:.....

Area:.....Project:.....Enumerator:.....

1. Dzina:.....Mudzi:.....
2. Mkazi/Mwamuna?.....Tsiku losankhidwa.....
3. Anthu angati?.....Akazi?.....Amuna?.....
4. Kodi ntchito mukugwirabe?.....Nonse?.....
5. Ngati ena anasiya ndi chifukwa chiani?.....
6. Munakonzapo malo owonongeka angati?.....
7. Nanga mapaipi owonongeka mumachita nawo chiani?.....
8. Munasungapo angati?.....
9. Nanga ndi chifukwa chiyani mapaipi amaonongeka?.....
10. Kodi zida zokonzera mapaipi muli nazo?.....
11. Ndi zida zANJI?.....
12. Munazipeza kuti?.....
13. Nanga zikatha mumachita chiyani?.....
14. Nanga ngati sanabweletse alangizi mumachita chiyani?.....
15. Kodi mumakhala ndi misonkhano?.....Inde/Kangati?.....
16. Ai/chifukwa chiyani?.....
17. Kodi misonkhano imakhala yokhudza chiyani?.....
18. Kodi maphunziro amene munalandira ndi okwanira?.....
19. Nanga mumadziwa bwanji kuti paipi yawonongeka?.....
20. Nanga mumachita chiyani?.....
21. Kodi anthu onse akukudziwani kuti mumakonza mapaipi ndinu?.....
22. Kodi paipi ikasweka inu osadziwa anthu amakuuzani?.....
23. Kodi mabvuto amene mumawapeza ndi otani?.....
24. Kodi alangizi amabwera kangati kudzakuonani?.....
25. Nanga mumathandizana nawo bwanji pa ntchito yanu?.....
26. Mumachita nawo misonkhano?.....
27. Maganizo anu ndi otani pa ntchito imeneyi?.....
28. Muli ndi sokambapo zina pa zimene mwafunsidwazi kapena zina ziri zonse zokhudza ntchitoyi?.....  
.....  
.....



copy 1: PWE(R)  
2: Controller

RECORD OF BREAKAGES

Project:..... Supervisor:.....Date:.....

DATE REPOR- TED	LINE	VILLAGE	PIPE SIZE	A.C.	P.V.C.	CAUSE OF BREAKAGE	DATE REPAI- RED

Copy 1: RWO  
 2: PWE(R)

TANK INSPECTION REPORT

Project:.....

Date:.....

NAME OF TANK	SIZE	DATE OF CLEANING		HEIGHT OF WATER CM.	HEIGHT OF SEDIMENT CM.	TIME OF INSPECTION	DOES TANK EVER		BALL VALVE WORKING?	REMARKS
		TANK	SURROUNDING				OVERFLOW HOW OFTEN HOW LONG	EMPTY HOW OFTEN HOW LONG		
SEDIMENT TANK										
1										
2										
3										
4										
5										
1										
2										
1										
2										
1										
2										



Copy 1: Supervisor  
 2: PWE(R)

STORES CONSUMPTION ON MAINTENANCE

S.M.A:..... PROJECT:..... REGION:..... PERIOD:.....

BRANCH	SOLVENT	CLEANING	HACKSAW	CLOTH	P.V.C.PIPE		A.C.PIPE		TAPS	WASHERS	GATE VALVES		OTHER FITTINGS	
	CEMENT (TINS)	FLUID (TINS)	BLADES	(M)	SIZE	LENGTH (M)	SIZE	LENGTH (M)			SIZE	NO.	DESCRIPTION	NO.